

Yearly Final

FORMAT Auto.C

Choose the most correct answer for each question. DO NOT WRITE ON TEST

*NOTE: IF ANSWER IS NOT GIVEN, DARKEN IN "E"

GOOD LUCK!!

I. BEARING PACK

1. TRUE OR FALSE (wheel)

Bearings are best lubed with white grease.

2. The cotter pin goes through a hole in:

- a) the race b) the cone c) the cage d) the spindle e) the drum

3. TRUE OR FALSE

When removing the inner seal the nut and washer should be reinstalled on the spindle and then the hub or drum pulled.

4. TRUE OR FALSE

The dust cover should be packed with grease.

5. TRUE OR FALSE

The spindle nut should be tightened as tight as possible and then backed off until there is some play.

IDENTIFICATION:

6, 7, 8, 9, 10, 11, 12, 13, 14, 15, 16,

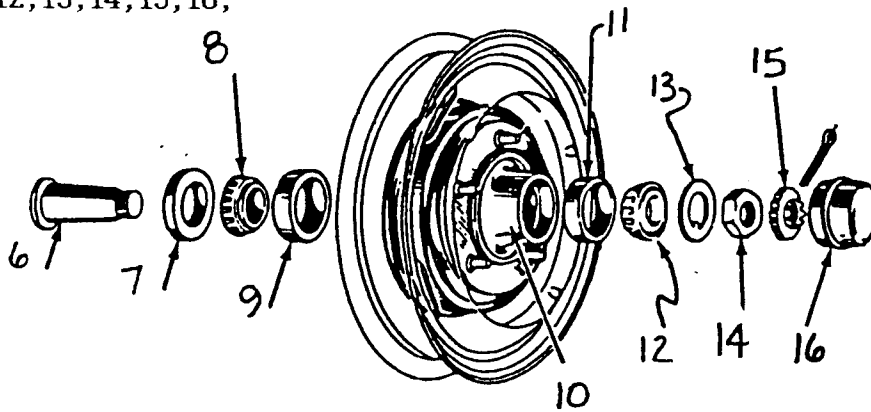

CHOOSE THE CORRECT TERM FOR THE ILLUSTRATION

- | | | |
|---------------|---------------|------------------|
| a) Caliper | a) Hub & Drum | a) Outer Cone |
| b) Cotter Pin | b) Inner cage | b) Outer Race |
| c) Dust Cover | c) Inner cone | c) Spindle |
| d) Cotter pin | d) Inner seal | d) Spindle Nut |
| e) Dust Cover | e) Keeper | e) Thrust Washer |

II. SAFETY

17. TRUE OR FALSE

Goggles are to be worn at all time when using the muffler cut-off tool.

18. TRUE OR FALSE

Wood chisels make good gasket scrapers.

19. TRUE OR FALSE

Oxygen and Acetylene are more explosive than straight oxygen.

20. TRUE OR FALSE

The tire machine can be hazardous to fingers.

21. TRUE OR FALSE

One should be especially careful around the rubber vibration belt that wraps around the drum when the brake lathe is running.

22. Acid hazards are present with which tools:

a) sockets b) dwell meters c) battery load testers d) hydrometers e) cap screws

23. TRUE OR FALSE

Battery acid can be neutralized with a solution of epon salt and water.

24. TRUE OR FALSE

There is no danger of fire when doing a compression test.

III. BRAKE LATHE

25. Brake drums can usually be turned up to:

a) .060 in. b) .060 feet c) diameter x bore d) .1000 e) 60 inches

26. Rotors can be refaced

a) .060 in. b) according to spec. c) until lugs disappear
d) at high speed e) only on drum surface

27. The part used to eliminate tool chatter on the brake lathe is:

a) the vibration belt b) tool wrench c) cones d) crossfeed
e) static adjuster

28. TRUE OR FALSE

Egg shaped drums are tapered.

29. Drums turned over the maximum can: (worst)

a) overheat b) explode c) warp d) stretch e) compress

30.TRUE OR FALSE

The shaft nut on the brake lathe is a reverse thread.

31.Which is the finest cut?

- a) 3/1000 inch
- b).050
- c) 1/4 inch
- d) 1/16in.
- e) .006 in.

IV.BRAKES

32.Which is not a method for bleeding brakes?

- a) pressure
- b) submerging hose in fluid
- c) gravity
- d) pump and hold
- e) air injection

33.TRUE OR FALSE

A pulsating pedal is due to air in the system.

34.TRUE OR FALSE

All drum brake systems self adjust.

35.The caliper is the same as _____ in a drum system.

- a) drum
- b) wheel cylinder
- c) brake shoe
- d) hold down
- e) return spring

36.Return springs are best removed with:

- a) channel locks
- b) a vise grip
- c) a punch
- d) a brake spring pliers
- e) a cylinder hone

37.The star wheel in a brake drum system is actually a

- a) wheel cylinder
- b) cup
- c) check valve
- d)brake adjuster
- e)bleeder

TRUE OR FALSE

38.Oil on the brake drums is best removed with parts cleaner solvent

IDENTIFICATION

39,40,41,42,43,44,45

- | | |
|--------------------|------------------|
| A)AIR VALVE | A)EXPANDER |
| B)BLEEDER SCREW | B)PISTON |
| C)CUP | C)RETAINER |
| D)DUST COVER(BOOT) | D)SPRING |
| E)END CAP | E)WHEEL CYLINDER |

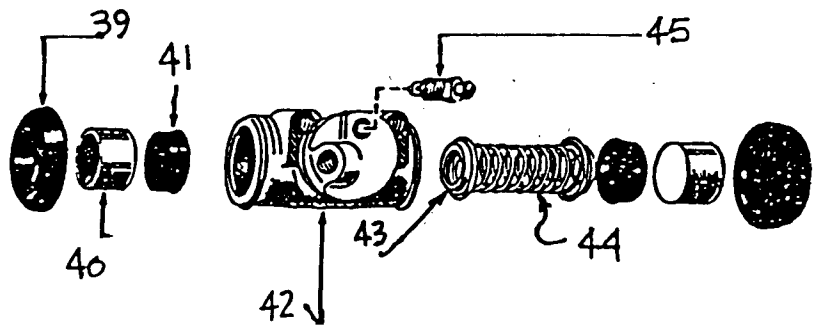

46.TRUE OR FALSE

It is good practice to disassemble both brakes on the same axle at the same time.

47. Which is NOT a part in the brake system?

- a) wheel cylinder
- b) master cylinder
- c) cup
- d) roll pin
- e) steel line

48. TRUE OR FALSE

Bleeding is a method for adding air to the brake lines.

IDENTIFICATION 49,50,51,52,53,54,55,56,57,

- | | |
|------------------------------------|-----------------------------------|
| A) ANCHOR PIN | A) PISTON PIN |
| B) ADJUSTER SLEEVE | B) PRIMARY SHOE |
| C) BACKING PLATE | C) RETURN SPRING |
| D) BRAKE SHOE RETAINER (HOLD DOWN) | D) SECONDARY SHOE |
| E) CUP | E) STAR WHEEL
(brake adjuster) |

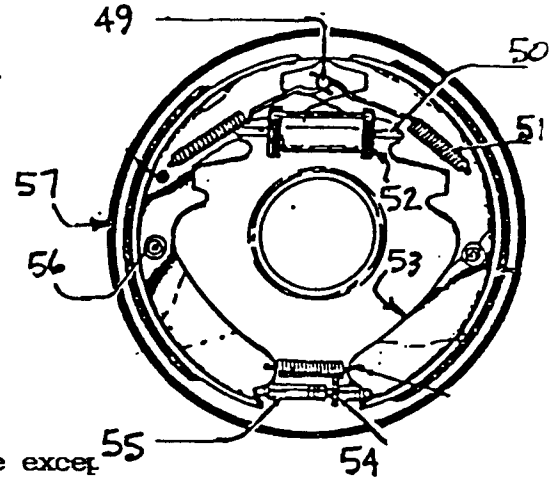

V. OIL CHANGE

58. All of the following are necessary for an oil change except

- a) oil filter
- b) fuel filter
- c) filter wrench
- d) sticker
- e) drain plug

59. True or False

All modern cars have a crankcase capacity of 5 quarts.

60. True or False

Oil should be added to within 1 qt. of capacity, the engine started, level checked, and remainder of oil added.

61. True or False

After changing oil. When the oil light goes out the oil filter is pressurized and all parts of the system are filled with oil.

62. Engine Oil level should be checked.

- a) with the car in drive
- b) with the car in neutral
- c) with the car in park
- d) with engine running
- e) after the engine has stopped

63. 10W30 is:

- a) a designation for gear lube
- b) trans lube
- c) straight weight oil
- d) multi-viscosity oil
- e) open gear lube

64. A good interval for oil change is:

- a) every 200 miles
- b) every 10,000 miles
- c) every 5,000 miles
- d) never
- e) every 2,000 miles

65. TRUE OR FALSE

Engine oil cools, lubricates, and cleans the engine

66.TRUE OR FALSE

The filter should be changed at every oil change

67.TRUE OR FALSE

A stripped out drain plug can be replaced with an oversized drain plug

VI.TOOLS

PICK THE BEST TOOLS FOR THE FOLLOWING OPERATIONS:

- | | |
|---------------------------------------|------------------------|
| 68.Removing cotter pin from spindle | a)Battery Load Tester |
| 69.Removing inner wheel seal | b)Brake Spoon |
| 70.Installing pistons(IMPACT) | c)Brake Spring Pliers |
| 71.Checking cylinders for wear(cone) | d)Channel Locks |
| 72.Checking battery specific gravity | e)Compression Gauge |
| 73.Checking tire pressure | a)Cylinder Taper Gauge |
| 74.Setting point gap(degrees) | b)Diagonal Cutters |
| 75.Checking resistance in plug wires | c)Dwell meter |
| 76.Setting spark plug gap | d)Filter Wrench |
| 77.Reading ignition timing | e)Headlight Aimer |
| 78.Measuring pressurein eng.cylinder | a)Hydrometer |
| 79.Measuring charging voltage | b)Mouth |
| 80.Headlight alignment | c)Ohmmeter |
| 81.Fuel Filter Test | d)Piece of Hose |
| 82.Removing oil filter | e)Ring Compressor |
| 83.Removing brake return spring | a)Screwdriver |
| 84.Adjusting brakes (drum-star wheel) | b)Spark Plug Gapper |
| 85.Removing spindle nut | c)Spindle Nut |
| 86.Installing difficult spark plug | d)Timing Light |
| 87.Adjusting air fuel mixture | e)Tire Pressure Gauge |

VII.TUNE-UP

88.TRUE OR FALSE

You must disconnect the primary wire to the coil before removing the distributor.

89.TRUE OR FALSE

If the distributor points are pitted you should replace the condensor.

90.TRUE OR FALSE

Brown deposits on the plugs mean that the engine is burning lean.

91. Normal compression test readings are:

- a) within 10% of high and low
- b) above 150psi
- c) according to manual
- d) all the same
- e) within 20% of two adjacent cylinders

92. TRUE OR FALSE

Valve timing is changed by turning the distributor.

93. The distributor can be checked with:

- a) compression gauge
- b) distributor machine
- c) timing light
- d) feeler gauge
- e) ohmmeter

94. TRUE OR FALSE

A feeler gauge is more accurate for setting points than a dwell meter.

95. Backfiring can be caused by:

- a) crossed spark plug wires
- b) lean mixture
- c) no air cleaner
- d) bad ballast resistor
- e) lost rotor

96. The following are necessary for an accurate compression test EXCEPT:

- a) fully charged battery
- b) point condition
- c) open choke
- d) tight seal at spark plug holes
- e) turning engine over same number of times

97. BTDC means

- a) position of piston before it hits top on compression stroke
- b) after top dead center
- c) degrees retarded
- d) cam angle
- e) point dwell

98. TRUE OR FALSE

A non-magnetic feeler gauge should be used when setting distributor air gap.

99. TRUE OR FALSE

A small amount of distributor cam lube should be placed against the rubbing block when installing a new set of points.

100. AIR GAP refers to the space:

- BETWEEN
- a) rotor and stator
 - b) point faces
 - c) armature and commutator
 - d) relay and ground
 - e) pickup and retractor

101. A low vacuum reading (3-5 in. mercury) usually means

- a) leaking intake manifold
- b) burnt valve
- c) late ignition timing
- d) low turbo boost
- e) electrical short

VIII. ENGINE MECHANICAL

102, 103, 104, 105, 106, 107, 108, 109, 110, 111,

- A) AIR CLEANER
- B) BELL HOUSING
- C) CRANKSHAFT SPROCKET
- D) CYLINDER
- E) CYLINDER HEAD

- A) DISTRIBUTOR
- B) FUEL PUMP
- C) LIFTER COVER
- D) OIL FILTER
- E) OIL PAN

- | | |
|------------------------|-----------------------|
| A) OIL PRESSURE SENDER | A) THERMOSTAT HOUSING |
| B) OIL PUMP | B) THERMOMETER |
| C) RING GEAR | C) TIMING COVER |
| D) ROCKER ARM COVER | D) VIBRATION DAMPER |
| E) TEMPERATURE SENDER | E) WATER PUMP |

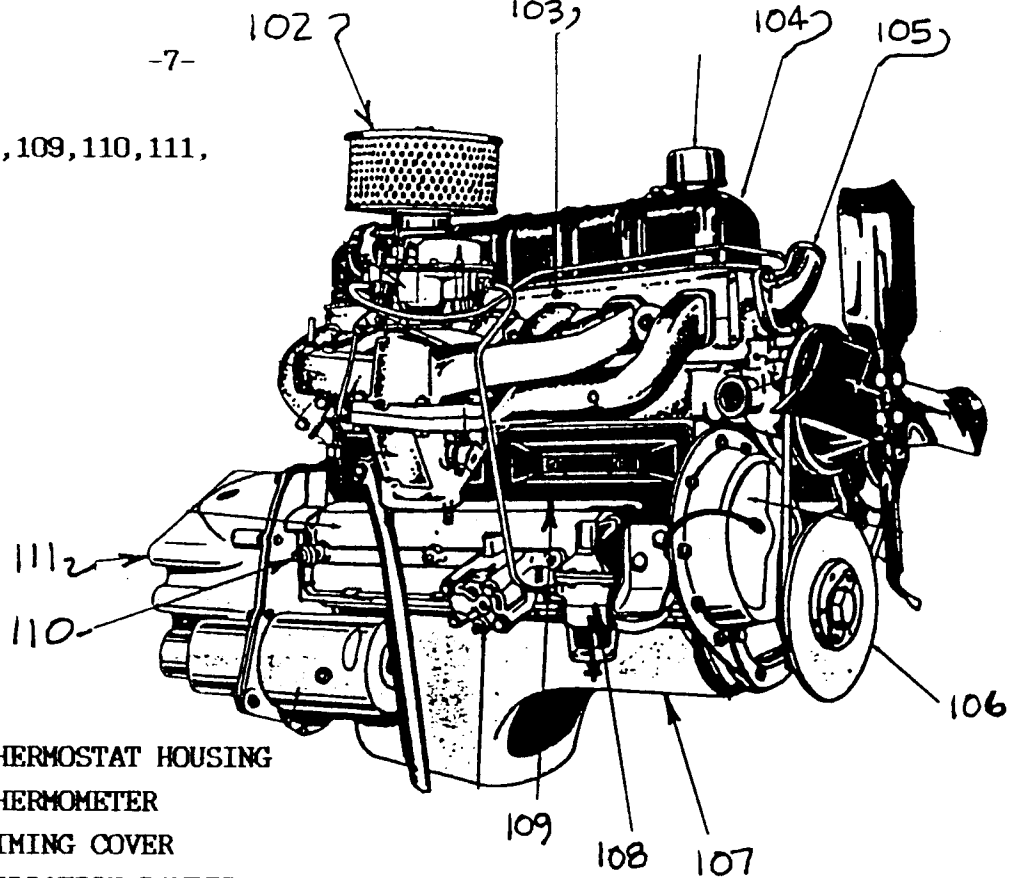

IDENTIFY THE ENGINE PARTS IN THE ILLUSTRATION

IX. EXHAUST SYSTEM

112. Piece that connects muffler to catalytic converter

113. Piece that connects the head to the exhaust pipe
- a) Catalyst
 - b) Catalytic converter
 - c) Crossover pipe
 - d) EGR Valve
 - e) Exh. manifold

114. Valve in the exhaust manifold that deflects hot exhaust gas to base of carburetor to warm fuel mixture.

115. Material that speeds up the rate of a chemical reaction.

116. Pipe connecting exhaust manifold to the muffler.

117. Chamber that exhaust passes to quiet loud sounds.

118. Pipe used in V type engines to pass exhaust from one side to the other .

119. Unit that contains platinum coated balls that changes carbon monoxide to carbon dioxide and water.

X. FUEL SYSTEM

120. Situation: Car doesn't start Compression OK Spark OK Timing OK
Fuel present at: Tank Intake-Fuel Pump Not Present at: Out- Fuel
Pump Out-Filter Carburetor

Problem is:

- a) pump diaphragm
- b) check valve
- c) plugged line
- d) clogged filter
- e) air in system

121. Testing instrument used to verify problem in

- a) fuel pump tester
- b) mouth
- c) vacuum gauge
- d) flowmeter
- e) venturi

122. Remedy of problem -#120

- a) replace the unit
- b) reuse the unit
- c) clean the unit
- d) bypass the unit
- e) fill it up

123. TRUE OR FALSE

The In Side of a fuel filter connects to the line coming from the carburetor.

124. TRUE OR FALSE

Most fuel pumps in carbureted cars run at 3-1/2 to 5 p.s.i. pressure.

125. When an engine first starts the unit that causes a higher fuel to air mixture is the:

- a) throttle plates
- b) float
- c) points
- d) vacuum advance
- e) choke

126. The unit that lets gasoline enter the bowl is:

- a) the throttle body
- b) needle and seat valve
- c) check valve
- d) choke plates
- e) fuel pump

127. A major casting in the carburetor is:

- a) float lever
- b) bowl
- c) air filter
- d) needle and seat
- e) deflector

128. TRUE OR FALSE

Electric fuel pumps are NEVER located in the fuel tank.

129. TRUE OR FALSE

Fuel Filters for carbureted fuel systems are physically larger.

130. TRUE OR FALSE

Many idling problems can be traced to moisture in the fuel.

131.TRUE OR FALSE

Gasoline loses its burnability after being in a cars tank several years.

132.TRUE OR FALSE

If given the choice a fuel pump will always suck air before fuel.

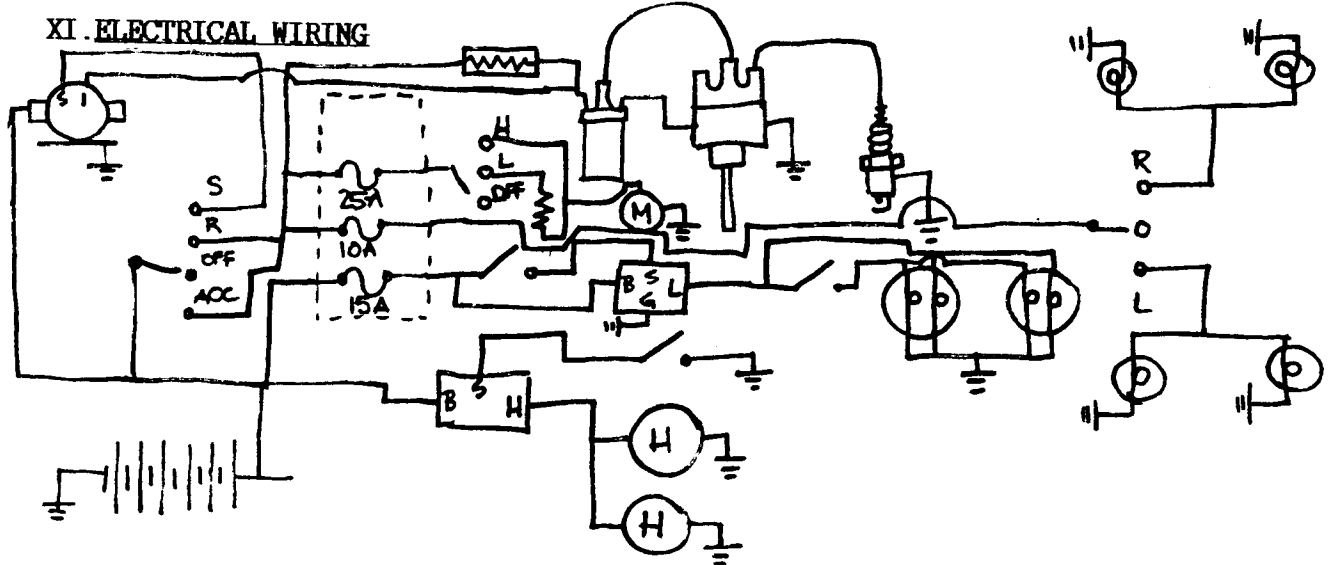

133.Heater circuit is correct and workable

134.Dual Horn Circuit is correct and workable

135.Turn signal Circuit is complete, correct and workable.

136.Headlight circuit is fused

137.Ignition circuit has 12volts in start, 6 volts in run.

A= YES B= NO

XII. METERS

Match the correct meter to following operations:

138.Test spark plug wires.

139.Test Continuity-dead circuit

140.Test Alternator Charging

141.Test Battery condition under working conditions

142.Set Point Gap

143.Set Idle Speed

144.Test Fuel Pump

145.Test Valve sealing in head

146.Set Carburetor idle air mixture

147.Test Strength of battery acid

a)Acid Meter

b)Battery Load tester

c)Compression gauge

d)dwelometer

e)Fuel Pump pressure tester

a)Hydrometer

b)Ohmmeter

c)Tachometer

d)Vacuum gauge

e)Voltmeter

XIII. TIRE MACHINE

148. TRUE OR FALSE

The valve core must be installed to seat the bead on the rim of a tire.

149. The tire machine has two foot pedals. One pedal rotates the center shaft and the other one operates the air blast and :

- a) breaks the bead
- b) puts air to the air hose
- c) sets the gauge
- d) pulls down the arm
- e) moves the seating bar.

150. TRUE OR FALSE

It is necessary to tighten the hold down cone to properly break the bead on a tire.

151. The best tool to remove a valve core is:

- a) diagonal cutters
- b) snap ring pliers
- c) needle nose pliers
- d) valve core tool
- e) Edward Scissorhands

152. TRUE OR FALSE

All tires should be filled up to the pressure rating stamped on the side of the tire.

153. TRUE OR FALSE

Deep dished wheels should be mounted upside down on the tire machine when breaking the bead.

154. To avoid ripping the sealing surface of the tire when removing or installing you should always put _____ on the bead.

- a) rubber lube
- b) Comet
- c) ammonia
- d) oil
- e) brake cleaner

XIV. CLEAN-UP

155. The best solution for cleaning up oil is:

- a) hot water, ammonia and soap
- b) hot water
- c) cold water
- d) a rag
- e) a broom

156. TRUE OR FALSE

Oil should always be wiped up before mopping.

157. Sector SIX is near:

- a) the sink
- b) the scope
- c) the blasters
- d) the loft
- e) the tool room

158. The LUBE bench is closest to:

- a) the drinking fountain
- b) the tool room
- c) the hoist
- d) the long bench
- e) the bead blasters

159. Brakes drums should be cleaned in solvent, flushed w/ hot water & THEN

- a) assembled
- b) blown dry
- c) wiped dry
- d) rewet
- e) cleaned with gas

XV. TIME CARDS

TRUE OR FALSE

160. The time cards should be marked on the BACK side when coming in.

161. Tests are worth

- a) 20%
- b) 50%
- c) 10%
- d) 30%
- e) 5%

162. The classroom grade is worth:

- a) 20%
- b) 50%
- c) 10%
- d) 30%
- e) 5%

XVI. ENGINE - MECHANICAL

163, 164, 165, 166, 167, 168, 169, 170, 171, 172, 173, 174, 175, 176, 177,

IDENTIFY PARTS IN ILLUSTRATION

- a) air cleaner
- b) baseplate gasket
- c) bell housing
- d) cylinder head
- e) distributor

- | | |
|----------------------------|---------------------------|
| a) exhaust manifold gasket | a) oil filter (cannister) |
| b) fuel pump | b) oil pan |
| c) counterweight | c) oil pump |
| d) float | d) oil strainer |
| e) fuel pump | e) pushrod |

- | | |
|-------------------------|----------------------------|
| a) intake manifold | a) rocker arm cover |
| b) journal | b) rocker arm cover gasket |
| c) main cap | c) valley cover |
| d) oil filler cap | d) vibration damper |
| e) oil filter (spin-on) | e) NOT GIVEN |

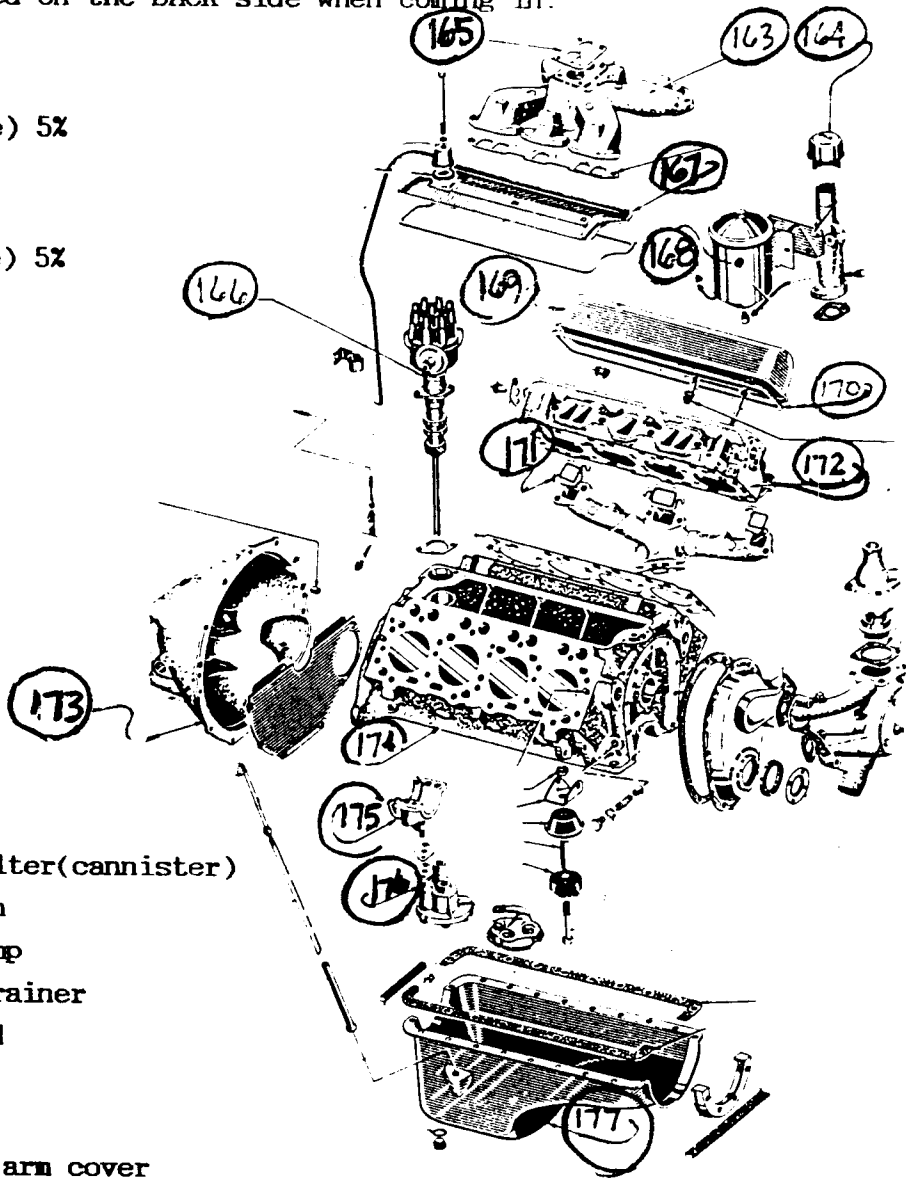

XVII. MECHANICAL SYSTEMS

Match the following terms with the correct system.

- | | |
|--------------------------|---------------------------|
| 178.Eccentric | a) Accessory Circuits |
| 179.Lobe | b) Air Conditioning |
| 180.Journal | c) Air Induction |
| 181.Race | d) Brakes |
| 182.Deck | e) Chassis and Suspension |
| 183.Header | a) Engine-Oiling |
| 184.Float | b) Engine-Mechanical |
| 185.Drive Gear | c) Exhaust |
| 186.Solenoid/Relay comb. | d) Fuel System |
| 187.Land | e) Starting-Electrical |
| 188.Guide(knurled) | a) Starting Mechanical |
| 189.Driven gear | b) Timing |
| 190.Ridge | c) Valve Train |
| | d) Wheels and Tires |
| XVIII. MANUALS | e) NOT GIVEN |

TRUE OR FALSE - THE FOLLOWING CAN BE FOUND IN THE MOTOR'S MANUALS

- 191.Engine tightening specs.
- 192.Engine displacement
- 193.Serial Number location
- 194.Crankcase capacity
- 195.Brake cylinder diameter
- 196.Ignition point part number.

XIX. LUBRICATION

Match the following parts with the correct lubricant

- | | |
|-----------------------------------|-------------------------|
| 197.Ball Joints | a) ATF |
| 198.Crankcase | b) Bearing Grease |
| 199.Shock absorber bushings | c) Chassis lube |
| 200.Door latches | d) Engine Oil |
| 201.Engine Bearings(assembly) | e) EP Gear Oil |
| 202.Piston Rings(assembly) | a) Graphite |
| 203.Wheel Bearings | b) Rubber Lube |
| 204.Oil filter | c) Stick Grease |
| 205.Differentials | d) STP & Oil |
| 206.Transmissions(automatic)TH350 | e) White Lithium Grease |

XXI. BELTS

A = Replace B = adjust

- 207. Cracks on side of belt
- 208. Fan on alternator turns by hand
- 209. Sides of belt hard and glazed
- 210. Belt sags in between pulleys

XX. HOSES

Rank hoses by size largest = A B C D E = smallest

- 211. PCV Hose
- 212. Fuel line
- 213. Heater hose
- 214. Radiator hose
- 215. Vacuum hose

XXI. CARBURETOR PARTS

IDENTIFY THE PARTS OF THE CARBURETOR

216, 217, 218, 219, 220, 221,

- a. air horn
- b. bowl
- c. jet
- d. needle and seat
- e. not given

- a. throttle body
- b. throttle plate
- c. venturi
- d. vent tube
- e. not given

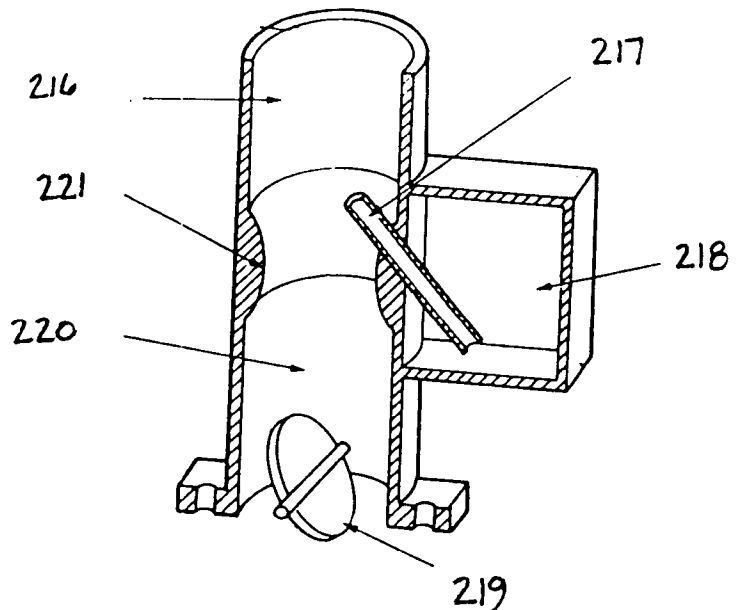

222. True or False

A stuck closed needle valve can contribute to a fire hazard.

XXII. TRANSMISSION

223. The smallest gear on the cluster is:

- a) first
- b) second
- c) third
- d) reverse
- e) synchro

224. The Brass part that helps eliminate gear grinding is:

- a) shift sleeve
- b) blocking ring
- c) first and reverse slider
- d) clutch
- e) synchronizer

225. The piece used to hold cluster bearings in place while installing the cluster gear into the case is called:

- a) dummy shaft
- b) pilot shaft
- c) bearing retainer
- d) race
- e) rollers

226. Units found in an electric overdrive unit are all the below EXCEPT:

- a) governor
- b) shift fork
- c) planetary gearset
- d) synchronizer
- e) solenoid

227. Bearings are found in all the following units EXCEPT:

- a) cluster gear
- b) pilot shaft
- c) synchronizer
- d) mainshaft
- e) tailshaft

228. A top loading transmission has:

- a) three levers
- b) a gasket on the side
- c) a cover on the top
- d) first and second in reverse order
- e) a pilot shaft on top

XXIII. CARBURETOR

229. The unit that sucks the gas into the barrel is called:

- a) throttle body
- b) vent
- c) accelerator pump
- d) venturi
- e) jet

230. The unit that lets fuel into the bowl is:

- a) gate valve
- b) check valve
- c) exhaust valve
- d) needle valve
- e) bowl valve

231. Secondary throttle plates are activated by either mechanical linkage or _____ assist

- a) pressure
- b) spring
- c) vacuum
- d) floating
- e) expandable

232. The BOTTOM casting of the carburetor is:

- a) the throttle body
- b) the vent bowl
- c) the fuel bowl
- d) the air horn
- e) the manifold heat riser

233. The assembly that squirts a stream of fuel into the primary venturi is called:

- a) venturi
- b) calibrator
- c) idle screw
- d) fast idle cam
- e) accelerator pump

XXIV. FRONT END

234. The angle that returns the steering wheel to center position is called

- a) caster b) camber c) king pin inclination d) toe in e) toe out

235. The angle that makes the tire narrower on the top than on the bottom is:

- a) caster b) camber c) king pin inclination d) toe in e) toe out

236. The angle that makes the fronts of the tires narrower than the rear edges is:

- a) caster b) camber c) king pin inclination d) toe in e) toe out

237. All the following are steering parts EXCEPT:

- a) spindle b) tie rod end c) king pin d) ball joint e) nose housing

238. A Macpherson strut takes the place of:

- a) tie rod and pitman arm b) spindle and ball joint c) shift sleeve and fork d) clutch and pressure plate e) contact point and rubbing block

XXV. EXHAUST

239. TRUE OR FALSE

The unit that quiets the exhaust sound is the cadillac converter.

240. TRUE OR FALSE

No gasket compound should be used on either side of the donut.

241. A straight pipe means:

- a) chambered exhaust b) baffles present c) glass packs d) no muffler e) use unleaded fuel only

242. The exhaust part that usually causes a popping in the tailpipe is:

- a) coil b) burnt exhaust valve c) bad guides d) bad points e) cracked manifold.

243. A crossover pipe:

- a) equalizes air pressure b) routes exhaust to one side in v engines c) maintains pressure in turbo charger d) heats up electric choke e) takes the place of the manifold in early cars.

XXVI. ELECTRICAL

244. A SHORT is

- a) a bad connector
- b) a bad ground
- c) a circuit that grounds too soon
- d) A bad armature
- e) pitted points

245. TRUE OR FALSE

You can sometimes find a short with a cheap compass and a flasher.

246. TRUE OR FALSE

The condensor in the distributor keeps the points from pitting.

247. The pick-up and stator are the same as:

- a) reluctor and module
- b) points and distributor cam
- c) coil and rotor
- d) cap and spark plug
- e) brush and armature

248. The part that charges the battery is:

- a) alternator
- b) starter
- c) voltage regulator
- d) hydrometer
- e) coil

XXVII. IN BETWEEN

249. DRIVESHAFT - DIFFERENTIAL YOKE

- a) bell housing
- b) universal joint
- c) clutch fork
- d) spline
- e) center bearing

250. PRESSURE PLATE - FLYWHEEL

- a) throw out bearing
- b) pilot bushing
- c) pilot shaft
- d) clutch disc
- e) nose housing

251. SPARK PLUG WIRE - COIL WIRE

- a) points
- b) condensor
- c) rotor
- d) spark plug
- e) nothing

252. SPINDLE - INNER CONE

- a) inner race
- b) cotter pin
- c) washer
- d) seal
- e) nothing

253. VALVE CORE - WHEEL

- a) cone
- b) spindle
- c) valve guide
- d) valve stem
- e) valve cap

XXVIII. DRIVELINE

254. TRUE OR FALSE

The slip spline is usually on the transmission side of the drive line.

255. TRUE OR FALSE

Front wheel drive cars use constant velocity joints in front of the differential.

256. TRUE OR FALSE

ATF-Dexron is the same as EP Gear Lube (SAE 90)

257. TRUE OR FALSE

The driveshaft connects the transmission to the differential.

258. TRUE OR FALSE

Most universal joints can be removed with a vise, hammer, and punches.

XXVIX. FUEL SYSTEM

259. IF a fuel pump has three tubes coming from its housing they are:

- a) in , out, return
- b) up, down, in
- c) carb, bowl, filter
- d) sender, housing, check valve
- e) through, after, before

260. TRUE OR FALSE

Diaphragm fuel pumps operate from a pulse from the eccentric on the camshaft.

261. TRUE OR FALSE

Big block engines require two fuel pumps.

262. TRUE OR FALSE

A fuel filter that permits flow in only one direction has an internal check valve.

263. TRUE OR FALSE

The sender for the fuel level gauge is located in the fuel tank.

XXX. COOLING SYSTEM

264. The part that regulates the engine operating temperature is:

- a) the shroud
- b) the thermostat
- c) the radiator
- d) the lower hose
- e) the radiator overflow tube

265. TRUE OR FALSE

Thermostat gaskets can be cut from the bottom of tin cans.

266. The rating of a thermostat is marked

- a) on the bottom of the pellet
- b) on the radiator cap
- c) on the upper hose
- d) on the clamp closest to the thermostat housing
- e) on the thermostat housing

267. The heater control valve regulates water flow to the:

- a) radiator
- b) thermostat housing
- c) heater core
- d) inside of the car
- e) lower radiator tank

268. The water jacket is located in:

- a) the radiator
- b) the thermostat housing
- c) the upper tank
- d) the engine block
- e) the overflow capacitor

XXXI. ENGINE TECHNICAL

269. TRUE OR FALSE

Exhaust valves usually wear out before intakes.

270. TRUE OR FALSE

Hemi headed engines have a wedge shaped combustion chamber.

271. TRUE OR FALSE

L head engines are flat head engines.

272. TRUE OR FALSE

Worn valve stems can usually be refaced by grinding at a larger diameter.

273. TIMING GEARS ARE LOCATED:

- a) in the oil pump
- b) in the head
- c) on the crankshaft and camshaft
- d) next to the flywheel
- e) between the vibration damper and pulley

274. TIMING CHAIN SETS come with:

- a) soft plugs
- b) pulley bolts
- c) degree wheel
- d) sprockets
- e) splines

XXXII. SPELLING

MARK A for CORRECT SPELLING

MARK B for WRONG SPELLING

275. Timing Chain

276. Carburetor Bowl

277. Fuel Pump

278. Caster

279. Eccentric

280. Cam lobe

281. Hammerberg

282. Catalyst

283. Wheel Bearing

284. Mechanical

XXXII.FUEL SUPPLY

285. TRUE OR FALSE

Most carburetted car fuel pumps are diaphragm type.

286. TRUE OR FALSE

Most fuel injected oil pumps are vane type.

287. A car that runs rough at idle following a fill-up might have:

- a) improper camber
- b) loose bearings
- c) fuel in the water
- d) gas in the oil
- e) water in the fuel

288. During a fuel pump test the gauge reads 5 psi and drops to zero at each pulse. THE PROBLEM IS:

- a) bad filter
- b) bad diaphragm
- c) bad check valve
- d) bad float
- e) bad tank

289. TRUE OR FALSE

Most modern day cars have non-vented gas caps.

290. Leaking gas tanks should be repaired:

- a) by a professional
- b) when full
- c) when filled with water
- d) when filled with sand
- e) in a bunker

XXXIII.FUEL SYSTEM- Carburetor

291. TRUE OR FALSE

The carburetor mixes fuel and air.

292. The pressure inside a venturi is _____ than in the bowl.

- a) the same
- b) less
- c) more

293. The best ratio of air to fuel is about:

- a) 2:1
- b) 14:1
- c) 3:1
- d) 1:1
- e) 9:1

294. The plate that richens the fuel mixture in the carburetor is:

- a) accelerator pump
- b) throttle plates
- c) choke
- d) metering rods
- e) float

295. TRUE OR FALSE

When starting a cold engine the accelerator pump primes the engine with a shot of fuel.

296. Idle air mixture can be adjusted by using all EXCEPT:

- a) vacuum gauge
- b) tachometer
- c) dwellmeter
- d) infra red meter
- e) ear

297. Normal vacuum reading at idle for a new engine is:

- a) 3 psi.
- b) 18-22 in.
- c) 5psi.
- d) 550 rpm
- e) 30 degrees

298. TRUE OR FALSE

A properly running engine should die when the idle air screws are turned all the way in.

299. TRUE OR FALSE

White smoke from the throat of the carburetor indicates raw fuel.

300. Blue smoke from the tailpipe means:

- a) rich mixture
- b) lean mixture
- c) bad piston rings/guides
- d) bad valve faces
- e) wrong firing order

301. TRUE OR FALSE

Most fuel filters have an "INLET" side and an "OUTLET" side.

302. All the following are types of fuel filters EXCEPT:

- a) copper wound
- b) in-line
- c) bronze
- d) paper
- e) cannister

303. TRUE OR FALSE

Excessive fuel consumption can be caused by a clogged exhaust passage in the intake manifold. (v type engines)

304. All of the following are types of automatic chokes EXCEPT:

- a) thermostatic coil
- b) electric
- c) water temp. activated
- d) cable

305. TRUE OR FALSE

A correctly adjusted automatic choke plate should have slight tension when the engine is HOT.

306. The unit that sets curb idle speed and closes the throttles when the engine stops is the:

- a) accelerator pump
- b) needle and seat valve
- c) float
- d) idle air screw
- e) idle/stop solenoid

XXXIV.BEST TOOLS

- | | |
|---------------------------------------|-----------------------------|
| 307. adjusting float level | a.air nozzle |
| 308. testing fuel filter | b.EAR |
| 309. cleaning air filter | c.50-100 PSI PRESSURE GAUGE |
| 310. adjusting idle air screws | d.MOUTH |
| 311. testing electric choke | e.PLIERS |
| 312. tightening baseplate to manifold | |
| 313. testing fuel pump pressure | a.PRESSURE/VACUUM GAUGE |
| 314. testing fuel gauge | b.SCREWDRIIVER |
| 315. testing idle stop solenoid | c.TACHOMETER |
| 316. testing air filter | d.TEST WIRE TO GROUND |
| 317. testing fast idle speed | e.TROUBLE LIGHT AND EYES |

318. The sensor that tells richness of the combustion mixture is the:
a) pressure sensor b) temperature sensor c) EGR Valve d)Oxygen sensor
e) timing sensor

319. The sensor that tells the computer WHEN to fire the injector is THE:
a) pressure sensor b) temperature sensor c) EGR Valve d)Oxygen sensor
e) timing sensor

320.TRUE OR FALSE

Carburetors are more efficient than electronic fuel injection systems.

XXXV.STEERING

321.TRUE OR FALSE

The piece that supports the steering linkage to the frame is the idler arm.

322.If you grab the sides of a jacked up tire you are checking.

- a) suspension b) steering c) steering and wheel bearing
d) shock absorbers e) tire pressure

323.If you push up on the center link and the center link and tie rod ends
and sleeve move together it is possible that the _____ is worn out.

- a) a frame b)idler arm c)steering column d)shock absorber e)ball joints

324.Steering wheels are best removed using:

- a) gear puller b) steering wheel puller c) jaw puller d) steel punch
e) impact driver

325.TRUE OR FALSE

Before removing a steering wheel it is important to mark the center of the steering wheel, and steering shaft with a center punch.

326.TRUE OR FALSE

Tie rod ends are removed from center links and spindles with a pickle fork.

327.TRUE OR FALSE

The height of a car can be changed by tightening or loosening a tension adjuster on a torsion bar.

328.Sway bars are mounted:

- a)directly to the frame b)to the shock absorbers c) in rubber sleeves or bushings d) to both upper control arms e) only in the center

329.TRUE OR FALSE

It is almost impossible to align a car if it has two different size tires on the same axle.

XXXVI.EXHAUST SYSTEM

330,331,332,333,334,335,336,337,338,339,

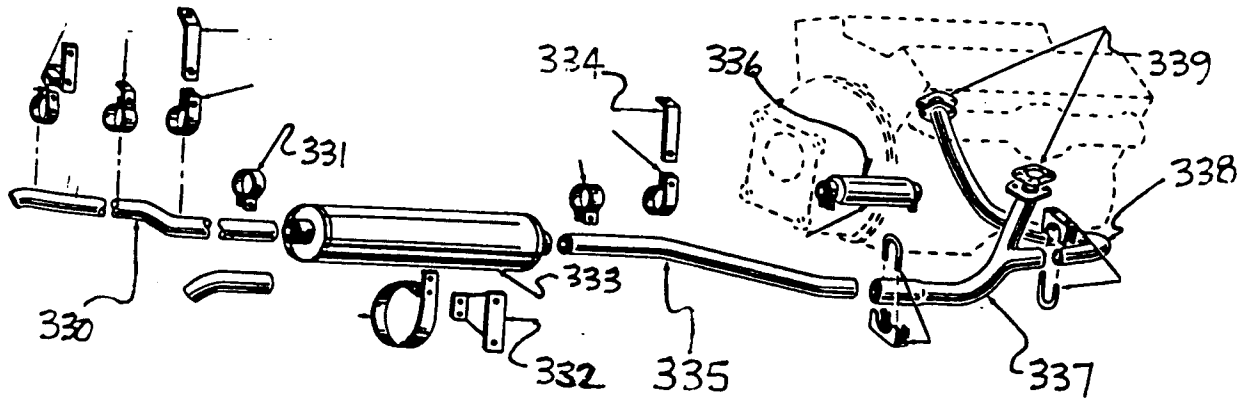

IDENTIFICATION

- A.CLAMP
- B.CROSSOVER PIPE
- C.EXHAUST BRACKET
- D.EXHAUST PIPE
- E.EXTENSION PIPE

- A.FLANGE GASKET
- B.HANGER
- C.HEAT SHIELD
- D.MUFFLER
- E.TAIL PIPE

XXXVII. TRANSMISSION PARTS

IDENTIFICATION

340, 341, 342, 343, 344, 345, 346, 347, 348, 349, 350, 351, 352, 353, 354, 355, 356, 357, 358.

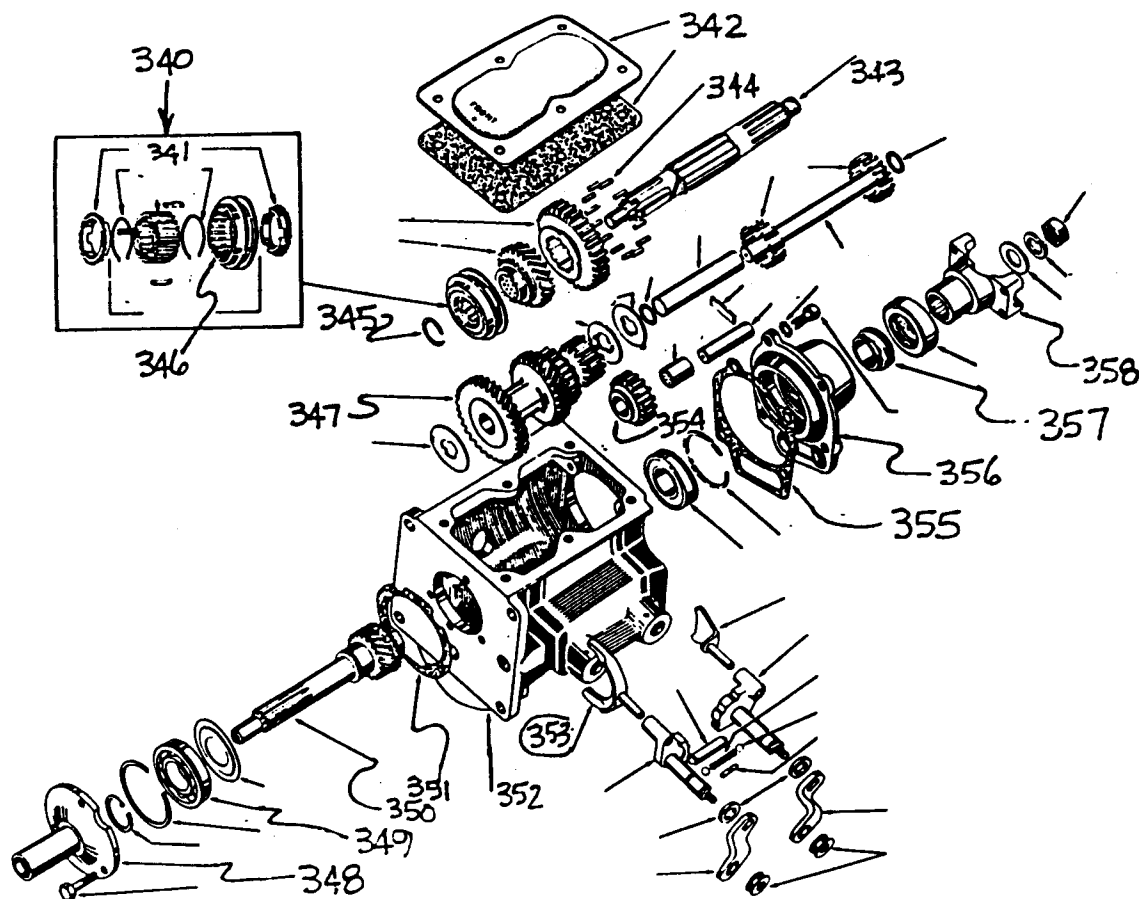

TYPICAL 3 SPEED TRANSMISSION—less OVERDRIVE

- | | |
|---------------------------|---------------------|
| B. BLOCKING RING | A. COVER & GASKET |
| C. BUSHING | B. GASKET |
| D. CLUSTER GEAR | C. GEARBOX |
| E. CLUSTER SHAFT | D. MAINSHAFT |
| | E. PILOT HOUSING |
| A. PILOT SHAFT | A. SHIFT SLEEVE |
| B. REAR TRANSMISSION SEAL | B. SNAP RING |
| C. REVERSE IDLER | C. SPEEDOMETER GEAR |
| D. ROLLER BEARING | D. TAIL HOUSING |
| E. SHIFT FORK | E. YOKE |
| E. NOT GIVEN | |

XXXVIII. ELECTRICAL WIRING

359, 360, 361, 362, 363, 364, 365, 366, 367, 368,

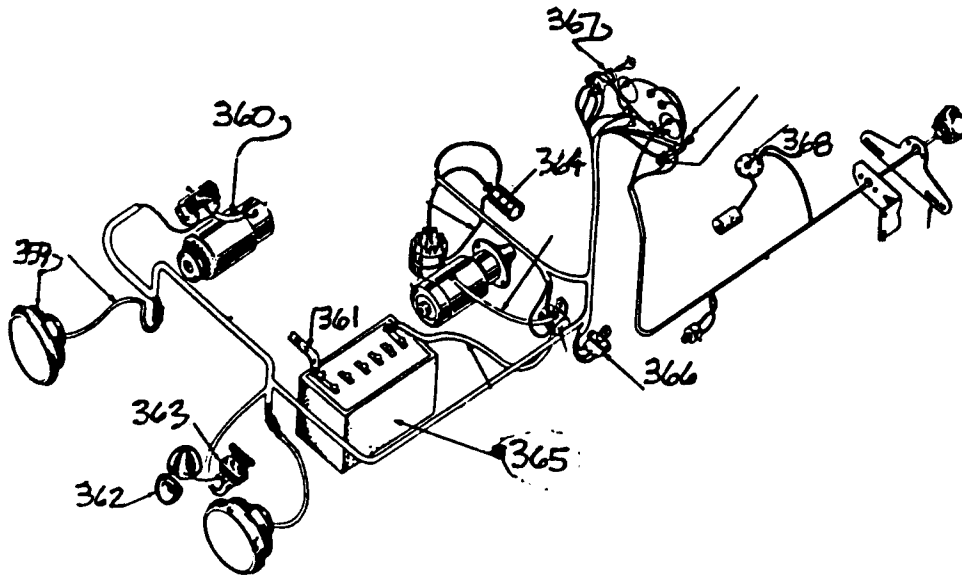

IDENTIFICATION

- A. BATTERY
- B. DIMMER SWITCH
- C. GROUND STRAP
- D. HEADLIGHT
- E. HORN

- A. STARTER
- B. STARTER RELAY
- C. STOP LIGHT SWITCH
- D. TAILLIGHT
- E. WIRING HARNESS

- A. FUEL TANK SENDER
- B. HORN RELAY
- C. IGNITION COIL
- D. IGNITION SWITCH
- E. PARKING LIGHT

XXXIX. PARTS IDENTIFICATION

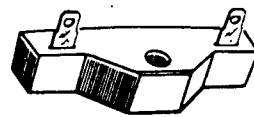

(369) PULL-OUT

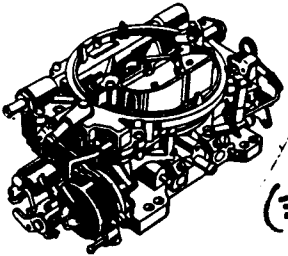

(370) IV CARBURETOR

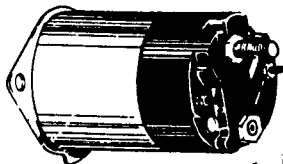

(371) DELCO SOLENOID

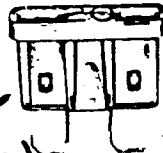

(372) FUSE

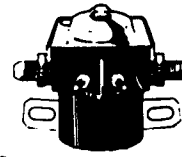

(373) N.S.S.

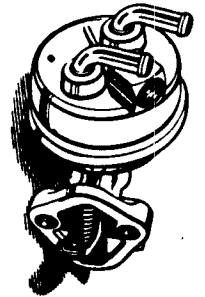

FUZZ BUSTER (374)



ROTOR (375)



HANGER (376)



PISTON RINGS (377)



CONDENSOR (378)



WATER PUMP (379)



(380) MANIFOLD GASKET



CLUTCH PACK (381)



(382) MUFFLER



(383) EXHAUST MANIFOLD

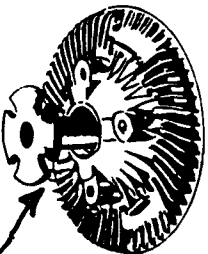

(385) FAN CLUTCH



CLIP (386)

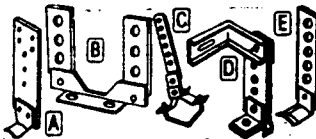

MUFFLER CLIPS (387)



TIMING BELT (388)



(384) CRANKSHAFT



TIE ROD (389)

XXXX. TOOL LOCATION

- 390. IMPACT WRENCH
- 391. CAM BEARING DRIVER
- 392. FILTER WRENCH
- 393. BATTERY FILLER
- 394. VALVE CORE TOOL
- 395. MACHINIST HAMMER
- 396. STETHESCOPE
- 397. HOLLANDER MANUAL
- 398. BLOW GUN

- A: CLASSROOM
- B: HAMMER BENCH
- C: LUBE RACK
- D: OFFICE
- E: PARTS ROOM
- A. RED BOX
- B. TIRE MACHINE
- C. TOOL ROOM
- D. VALVE BENCH
- E. NOT GIVEN

XXXXI. FASTENERS

IDENTIFICATION

399, 400, 401, 402, 403, 404, 405, 406, 407, 408, 409, 410, 411, 412, 413, 414, 415, 416, 417, 418,



- A. ACORN NUT
- B. ALLEN HEAD BOLT
- C. CASTELLATED NUT
- D. CLEVIS PIN
- E. COTTER PIN

- A. FLAT WASHER
- B. HEX HEAD CAP SCREW
- C. KEY
- D. JAM NUT
- E. PHILLIPS HEAD SCREW

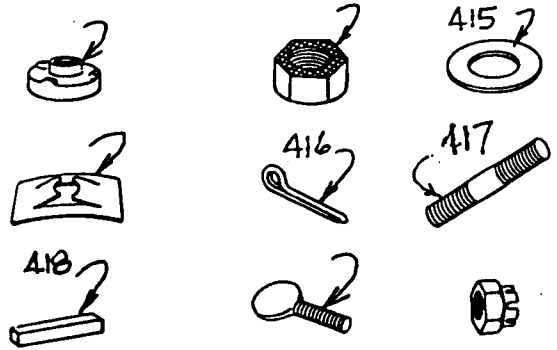

- A. SELF-LOCKING NUT
- B. SET SCREW
- C. SHAKEPRUF-LOCK WASHER
- D. SHAKEPRUF-NUT
- E. SNAP RING

- A. SPLIT LOCK WASHER
- B. STOVE BOLT
- C. STUD
- D. THUMBSCREW
- E. WING NUT

XXXXII. BEST PRECISION MEASURING TOOL

- 419. INSIDE DIAMETER OF HUB
- 420. POINT GAP
- 421. CRANKSHAFT END PLAY
- 422. CYLINDER TAPER
- 423. HEAD WARPAGE
- 424. VALVE STEM OUT OF ROUND
- 425. COOLANT TEMPERATURE
- 426. CRANKSHAFT JOURNAL DIAMETER
- 427. BEARING OIL CLEARANCE
- 428. BRAKE DRUM OVERSIZE
- 429. FRAME HEIGHT
- 430. CAMBER ANGLE

- E. NOT GIVEN
- A. ALIGNMENT HEAD
- B. BRAKE MICROMETER
- C. CALIPER (INSIDE READ)
- D. CYLINDER TAPER GAUGE
- E. DIAL INDICATOR
- A. FEELER GAUGE
- B. MICROMETER
- C. PLASTIGAGE
- D. RULER
- E. STRAIGHTEDGE/ FEELER GAUGE

XXXXIII. CLUTCH IDENTIFICATION

431, 432, 433, 434, 435, 436, 437, 438, 439, 440,

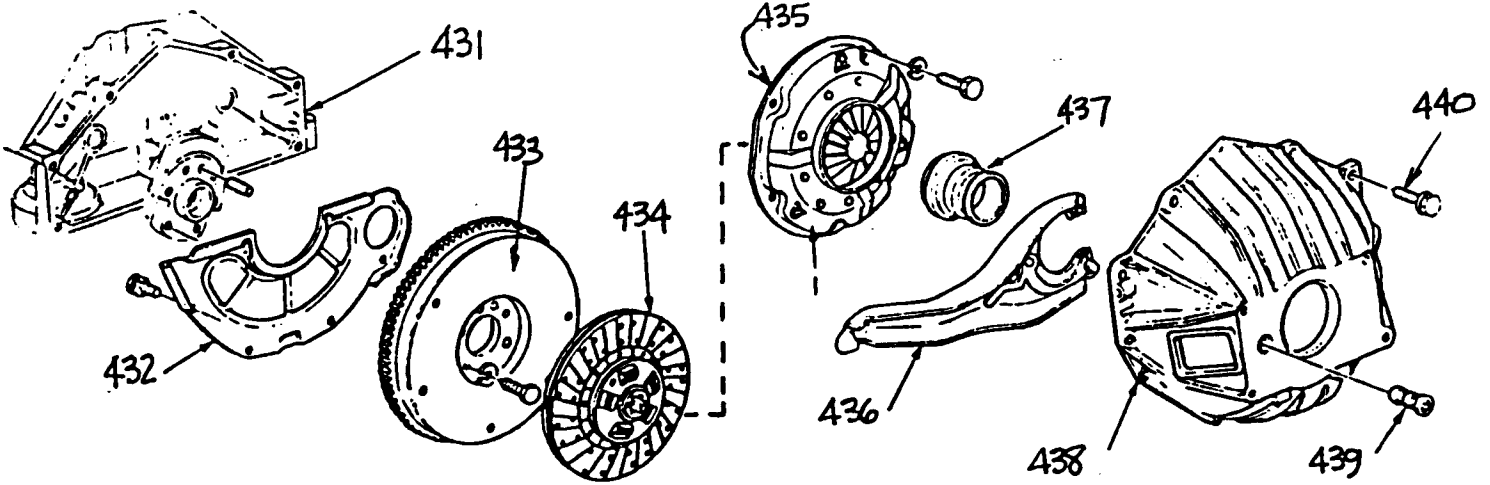

- A. BELL HOUSING
- B. CLUTCH DISC
- C. CLUTCH FORK
- D. CLUTCH FORK STUD
- E. ENGINE BLOCK

- A. FLYWHEEL
- B. INSPECTION COVER
- C. PILOT BUSHING
- D. PRESSURE PLATE
- E. THROW OUT BEARING

XXXXIV. COOLING SYSTEM IDENTIFICATION

441, 442, 443, 444, 445, 446, 447, 448, 449, 450,

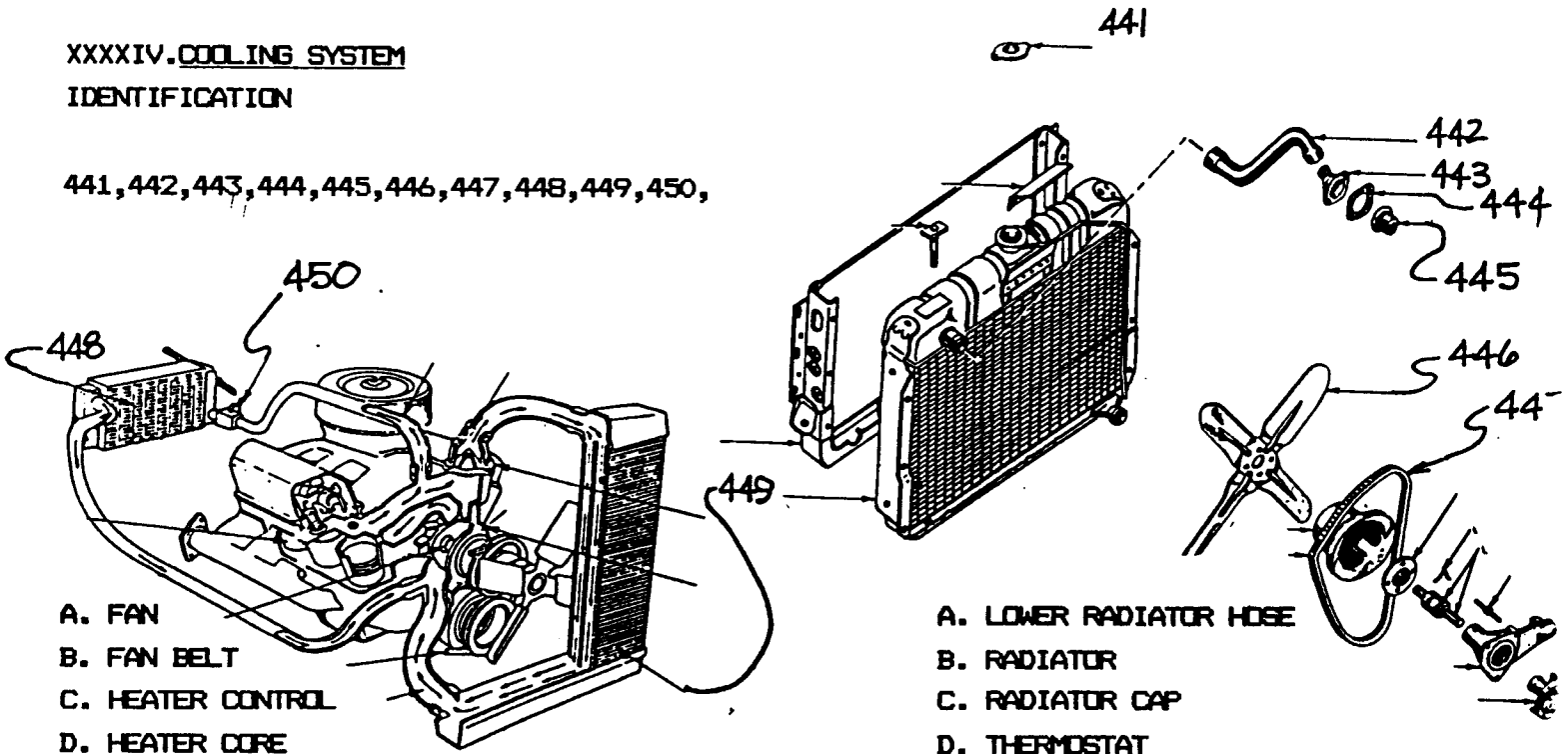

- A. FAN
- B. FAN BELT
- C. HEATER CONTROL
- D. HEATER CORE
- E. GASKET

- A. LOWER RADIATOR HOSE
- B. RADIATOR
- C. RADIATOR CAP
- D. THERMOSTAT
- E. THERMOSTAT HOUSING

E. NOT GIVEN

E. UPPER RADIATOR HOSE

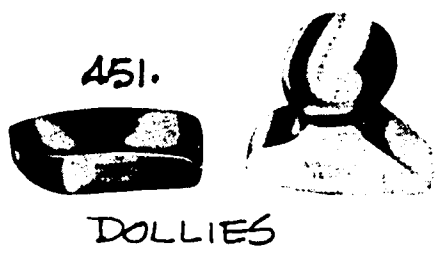

451.

DOLLIES

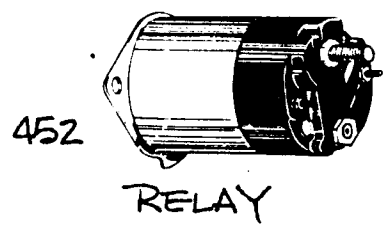

452

RELAY

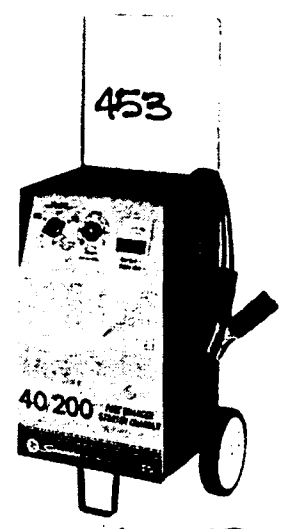

453

ARC WELDER

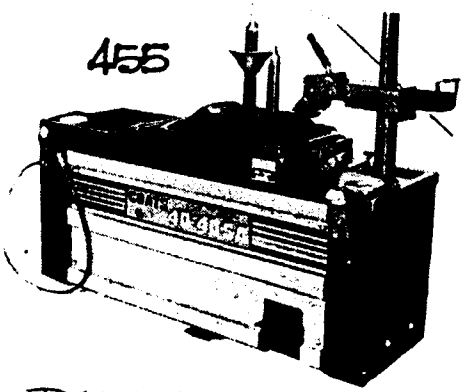

455

BALANCER

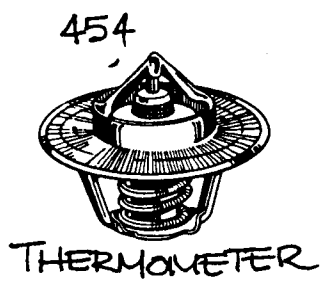

454

THERMOMETER

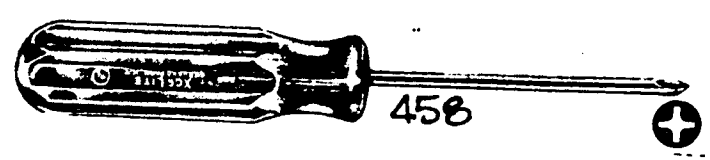

458

CLUTCH TIP SCREWDRIVER

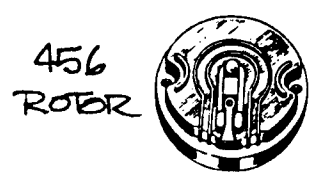

456 ROTOR

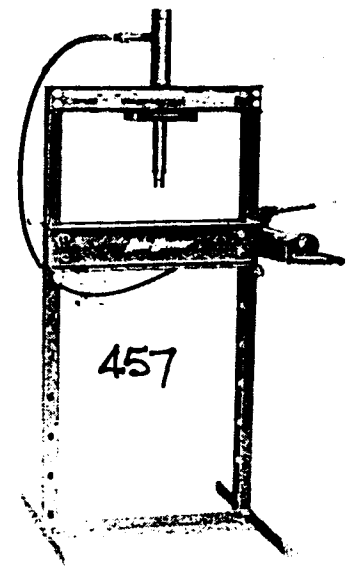

457

ARBOR PRESS

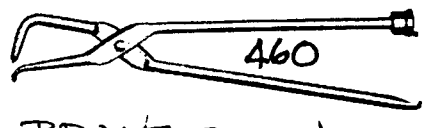

460

BRAKE SPOON

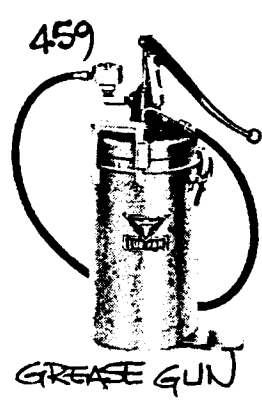

459

GREASE GUN

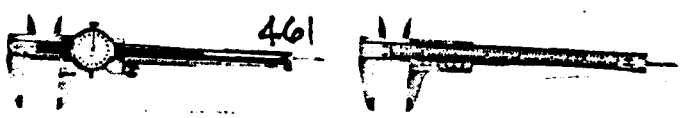

461

MICROMETERS



462

DWELL METER



463

BATTERY TERMINAL



A1

464

ALLEN SOCKETS

465

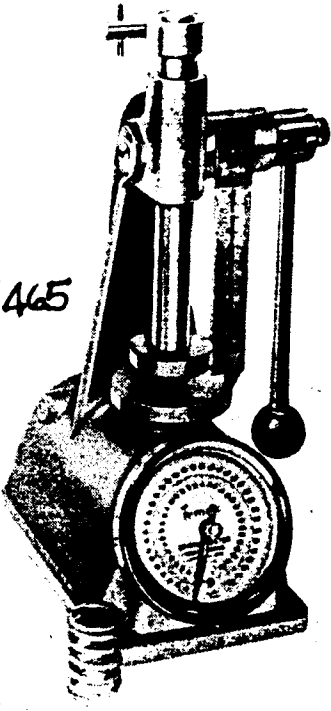

VALVE SPRING TESTER

466



BATTERY FILLER

467

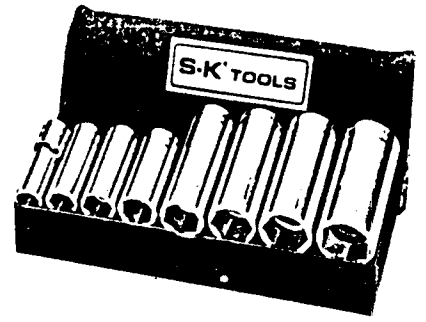

DEEP SOCKETS

469

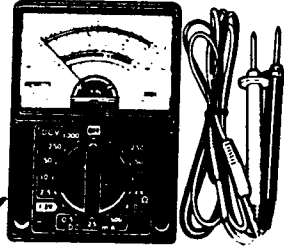

MULTIMETER

468

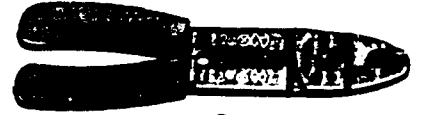

CRIMPER

470

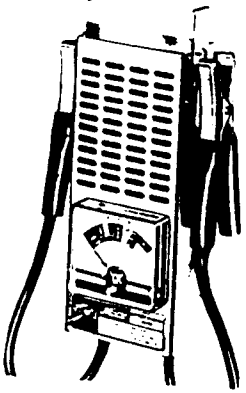

BATTERY LOAD TESTER

471

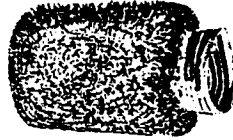

CHAMOIS

472

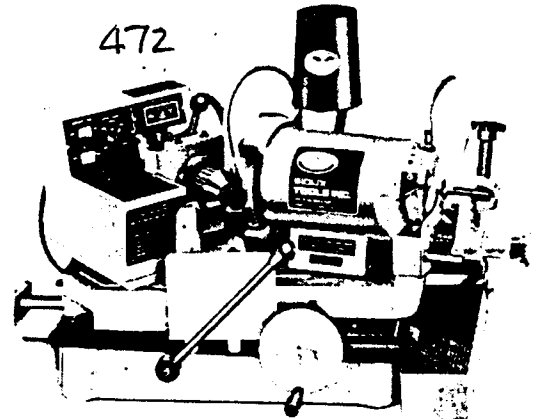

VALVE GUIDE KNURLER

473

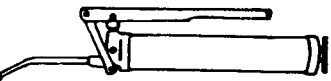

GREASE GUN

474

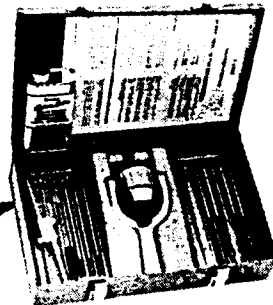

VALVE GUIDE KNURLER

475

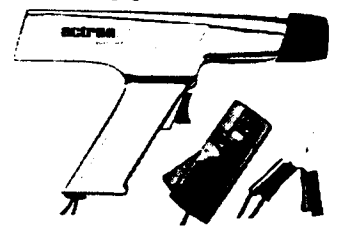

TIMING LIGHT

476



VALVE CORE TOOL

477

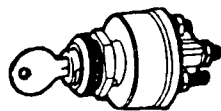

IGNITION SWITCH

478

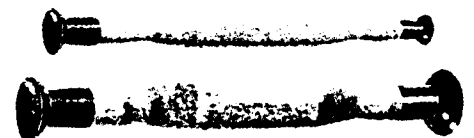

VALVE LAPPERS

479

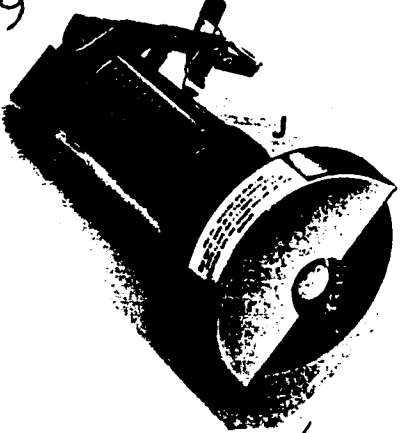

MUFFLER CUT/OFF TOOL

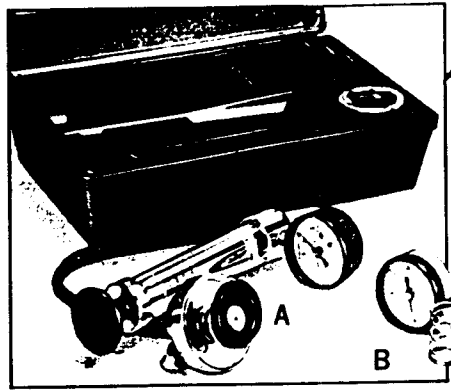

RADIATOR PRESSURE TESTER

480

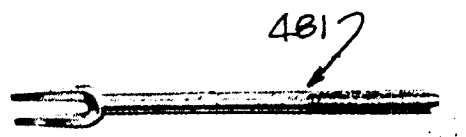

THE ROD SEPARATOR

481

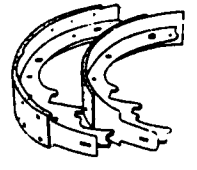

482
BRAKE PADS

483



CYLINDER TAPER GAGE

484

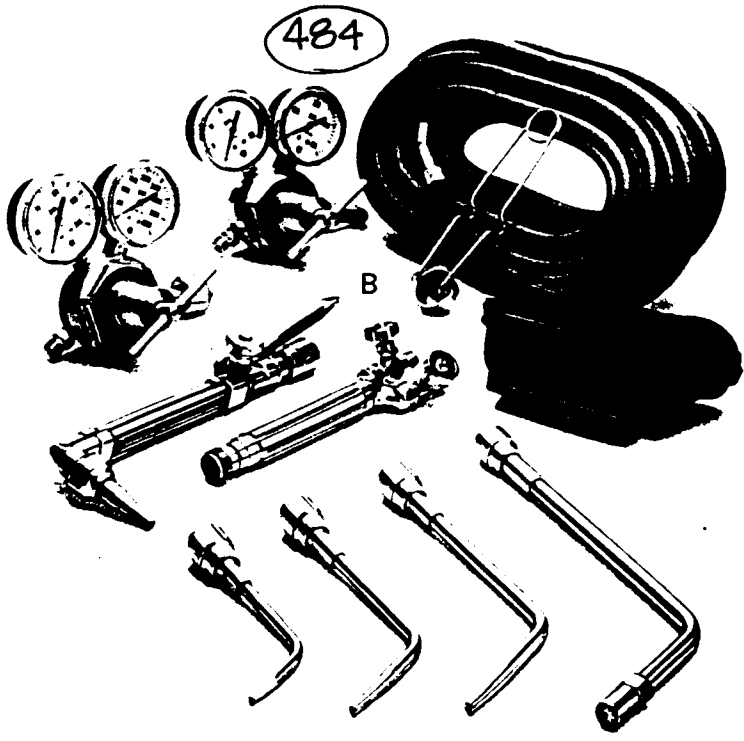

OXY-ACETYLENE WELDER

485



PENETRATING OIL

486

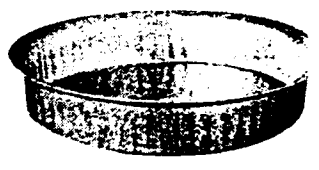

RADIATOR FILLER

487

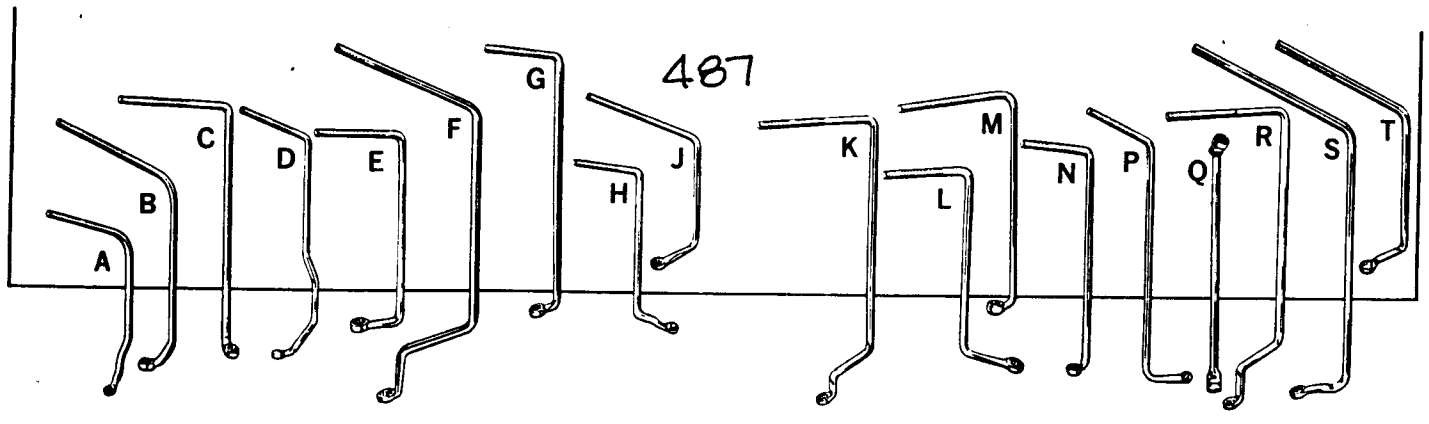

CROWFOOT WRENCHES

488

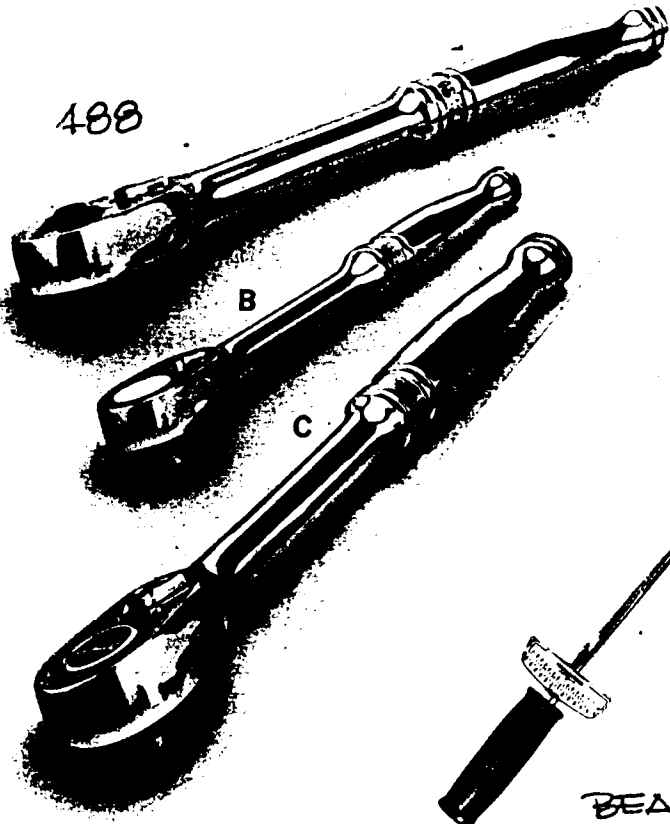

B

C

489

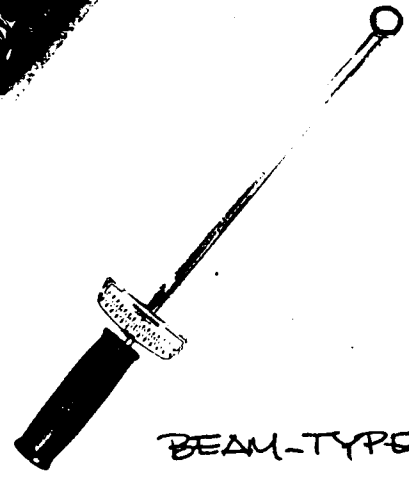

BEAM-TYPE TORQUE WRENCH



K

R2D2

491

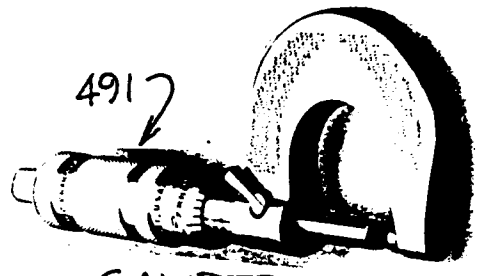

CALIPER

RATCHETS

Fed. Spec. GGG-W-641E

493

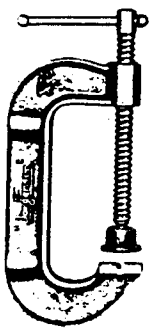

C-CLAMP

492

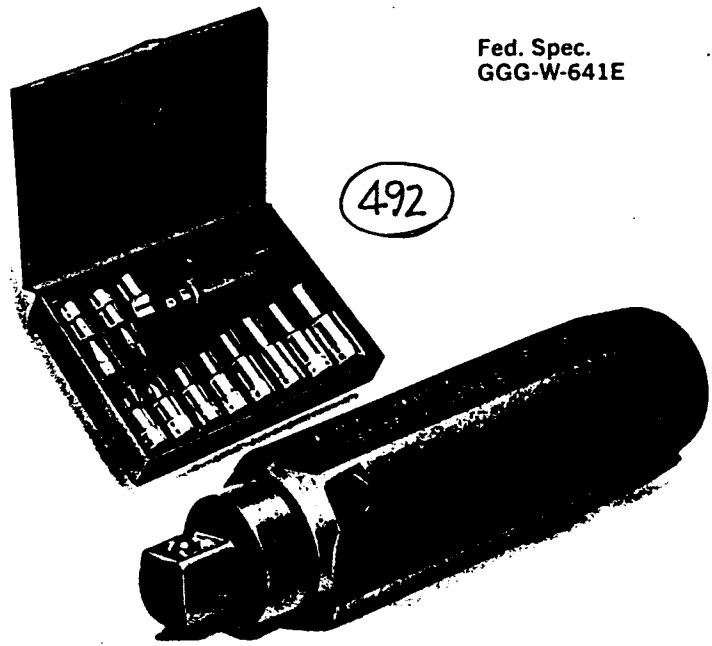

IMPACT DRIVER

494

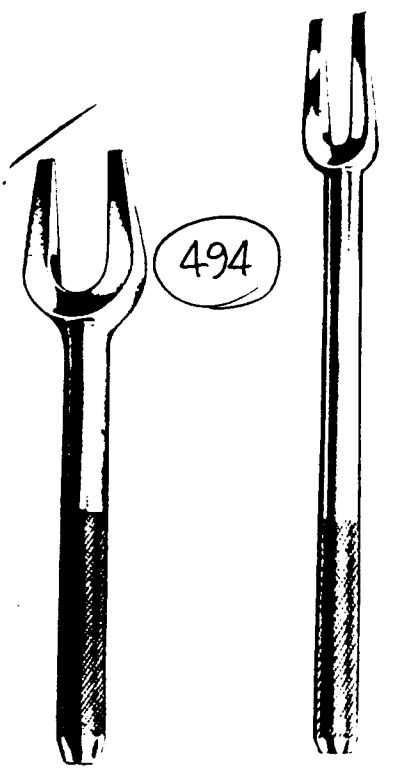

TUNING FORKS

495

60°

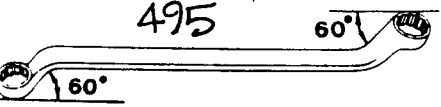

COMBINATION WRENCH

496



PUTTY KNIFE

497



PIN PUNCH

-32-

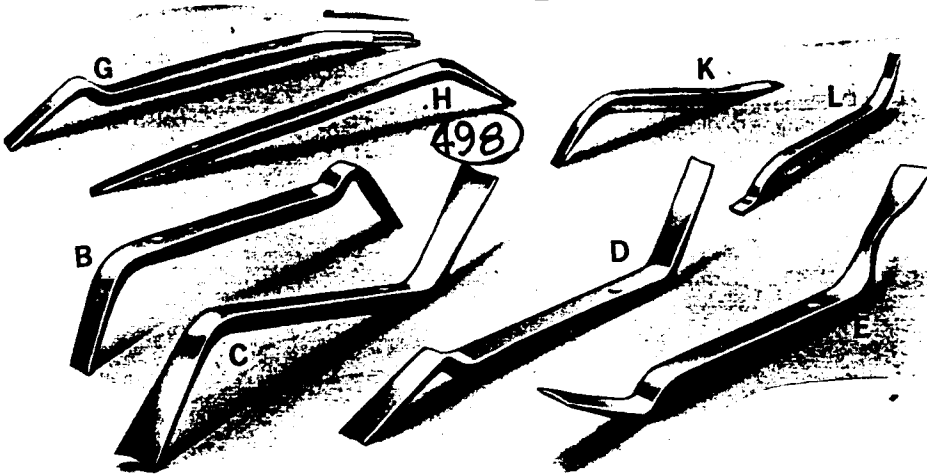

BRAKE SPOONS

499

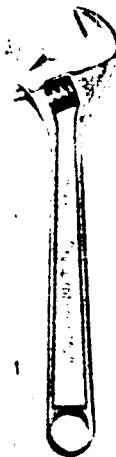

CHANNEL LOCKS

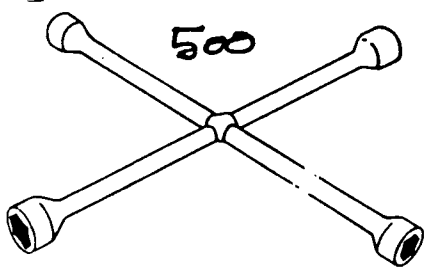

LUG WRENCH

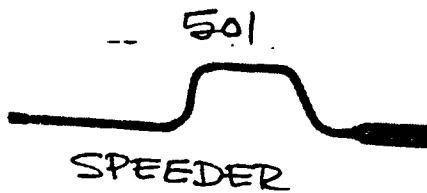

SPEEDER

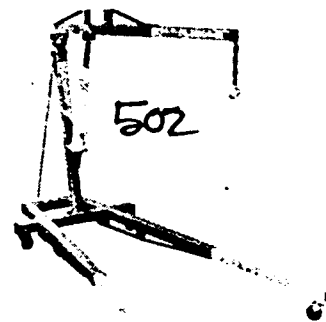

CHERRY PICKER



VACUUM CLEANER

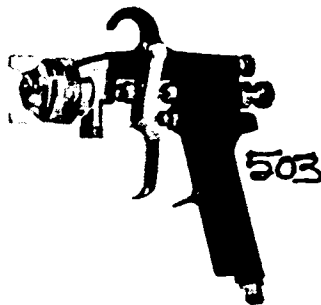

SPRAY GUN

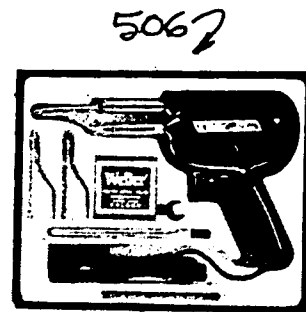

TIMING LIGHT

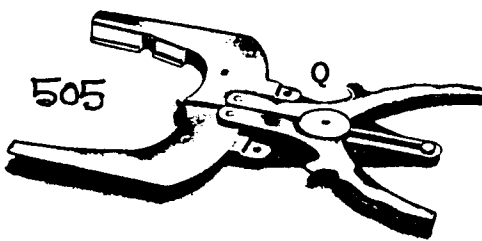

RING COMPRESSER

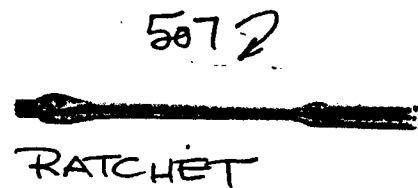

RATCHET

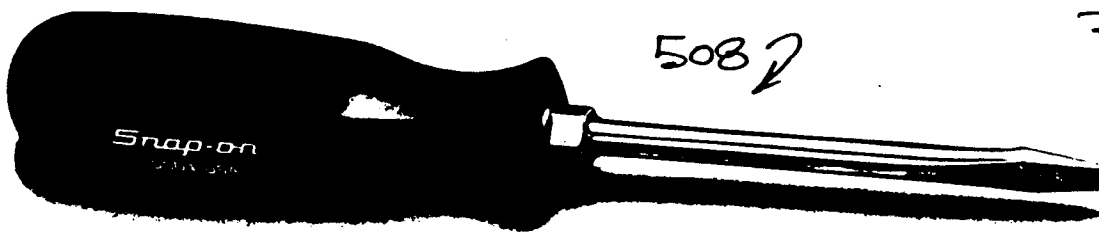

PLAIN-TIP SCREWDRIVER

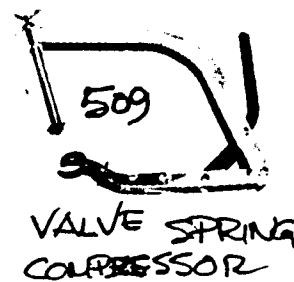

VALVE SPRING COMPRESSOR



510

CROWFOOT
WRENCHES

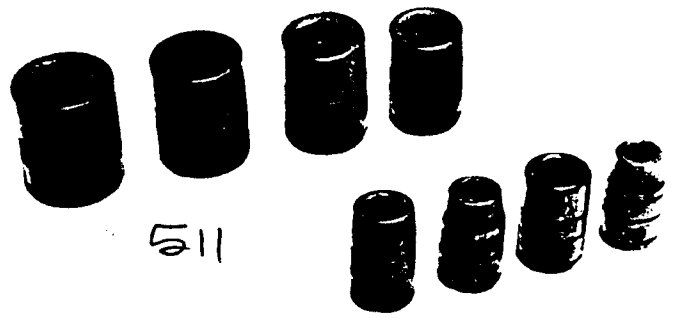

511

IMPACT SOCKETS

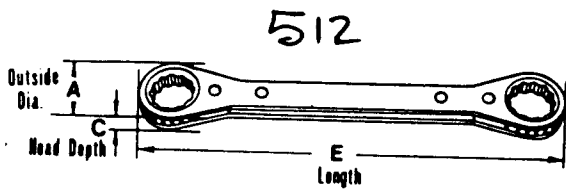

512

OPEN END WRENCH

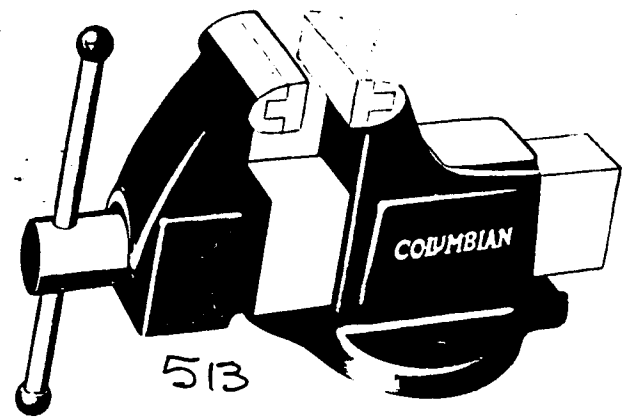

513

VICE

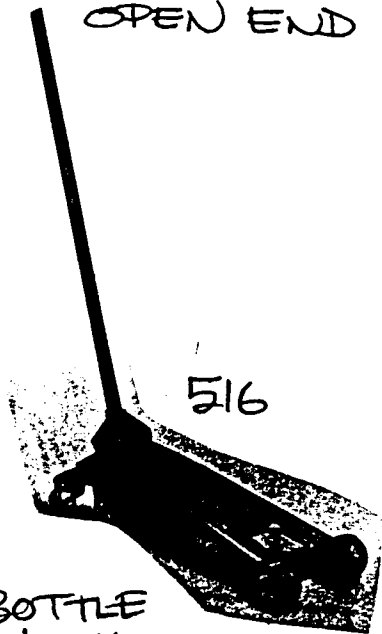

516

BOTTLE
JACK

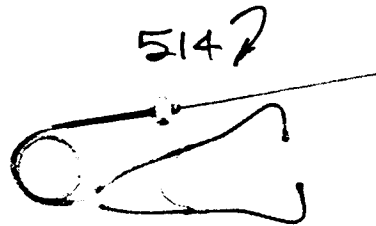

514?

STETHESCOPE

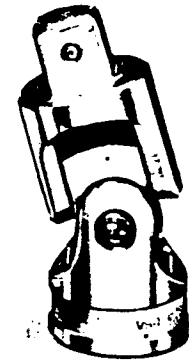

515

U-JOINT EXTENSION

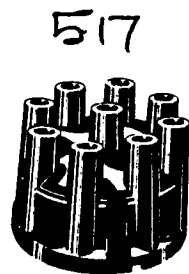

517

SOLENOID

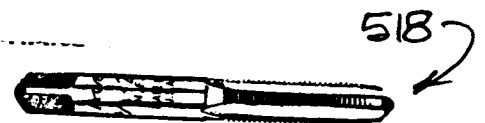

518

DIE

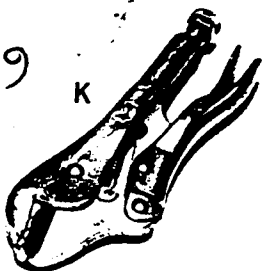

519

K

VICE GRIP

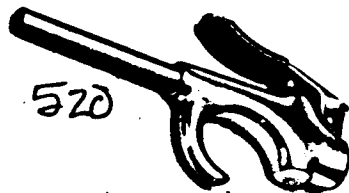

520

BLOW GUN

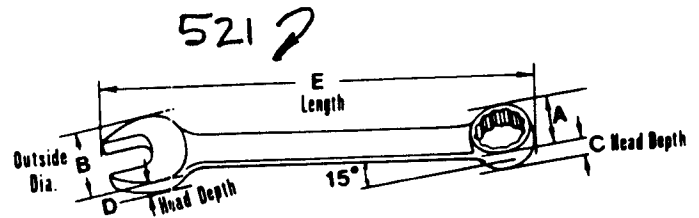

521?

COMBINATION WRENCH

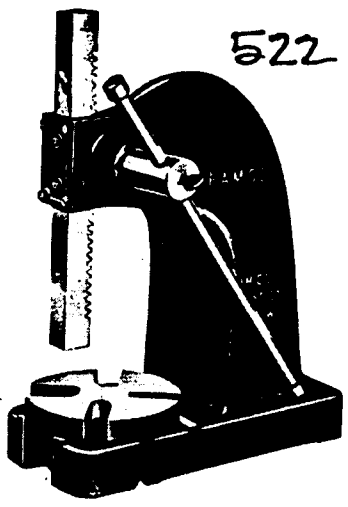

522

ARBOR PRESS

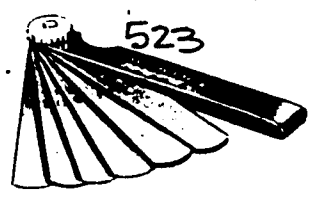

523

SPARK PLUG WIRE GAGE

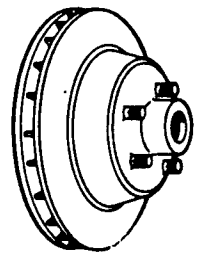

524 ?

BRAKE DRUM



525

PLIERS

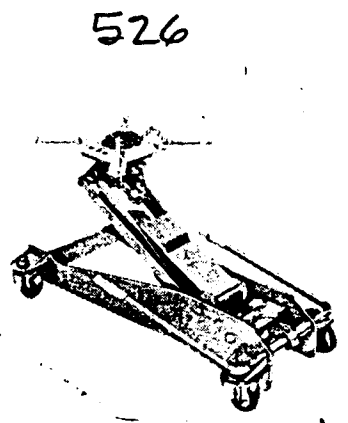
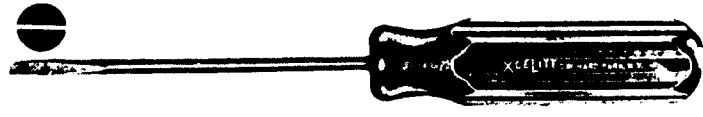

526

TRANSMISSION JACK

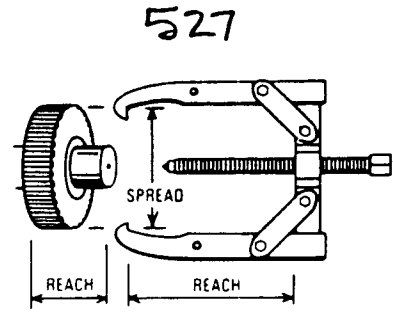

527

PLATE PULLER



528

LINEMAN'S PLIERS

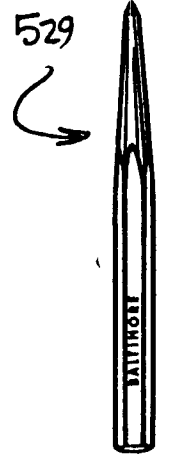

529

COLD CHISEL

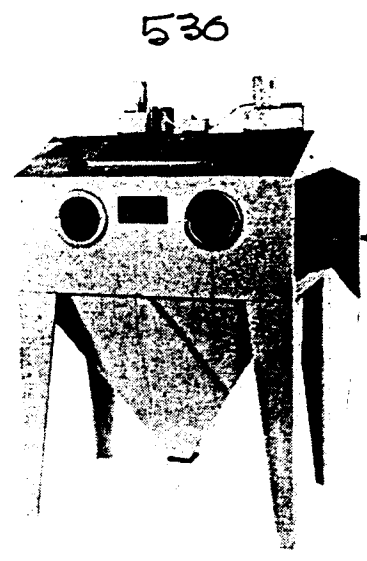

530

BEAD BLASTER



531 ?

MICROMETERS

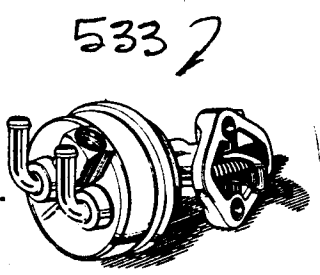

533 ?

FUEL PUMP

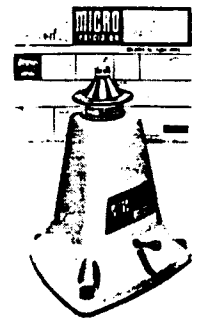

532 ?

WHEEL BALANCER

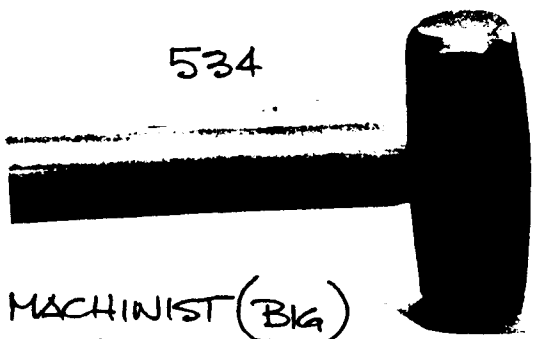

534

MACHINIST (BIG) HAMMER

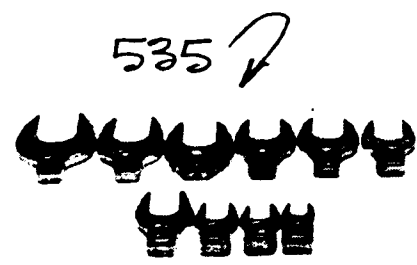

535 ?

UNIVERSAL WRENCHES

536 ↗

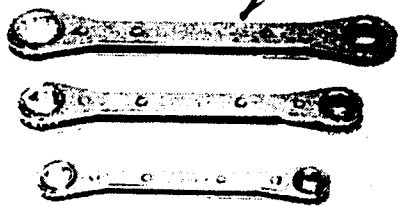

RATCHETING BOX END WRENCHES

537 ↗



DIE

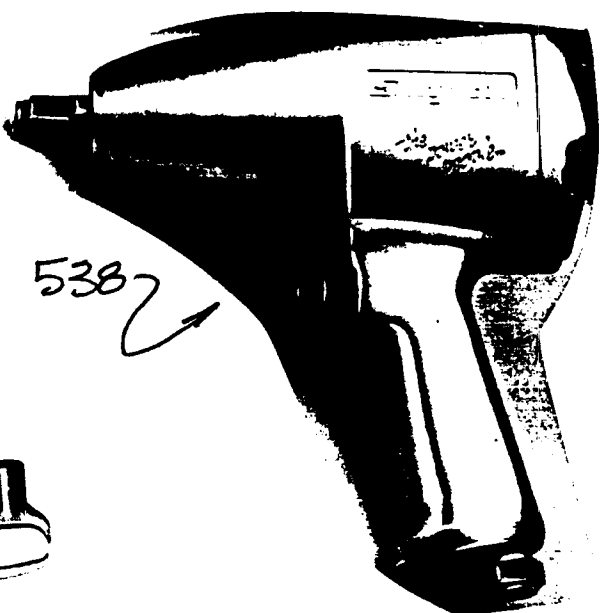

538 ↗

IMPACT WRENCH

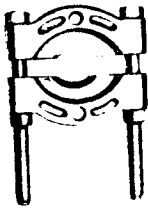

540 ↗

BEARING SPLITTER

539 ↗

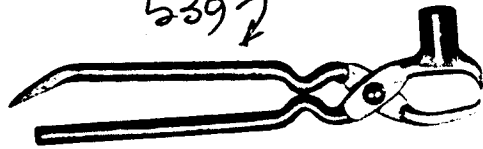

WHEEL WEIGHT TOOL

541 ↗



POINT FILE

542 ↗



ARC WELDER

543 ↗



COLD CHISEL

544 ↗

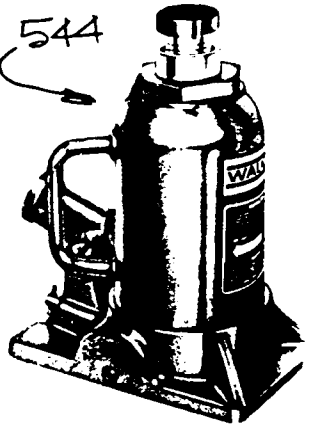

BOTTLE JACK

545 ↗

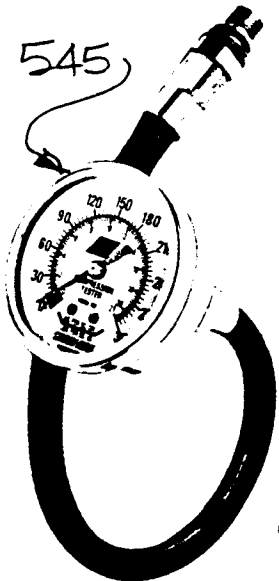

OEM 1073

VACUUM GAUGE

546 ↗



RING COMPRESSOR

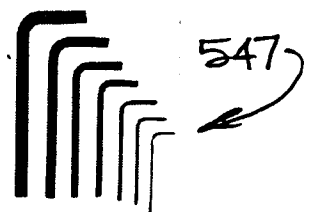

547 ↗

ALLEN WRENCHES

548 ↗

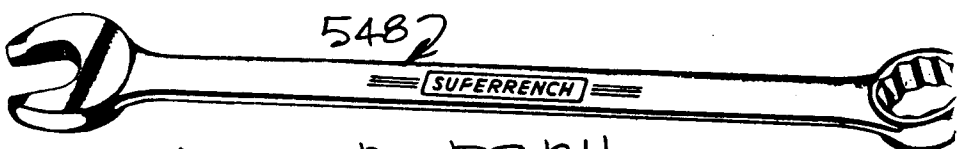

BOX-END WRENCH



DIAGONAL CUTTERS

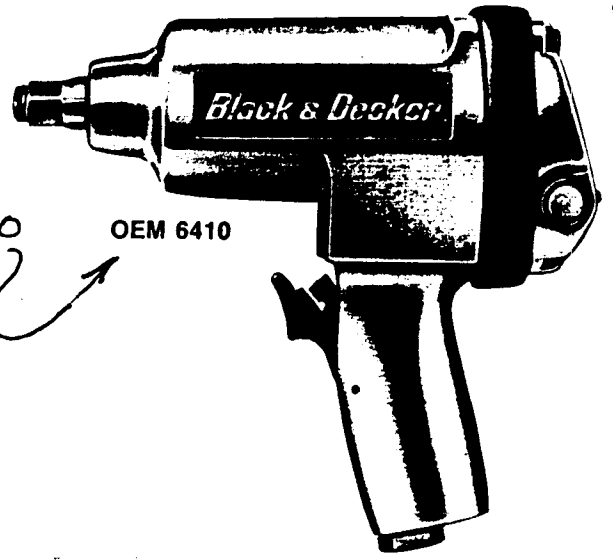

IMPACT DRIVER

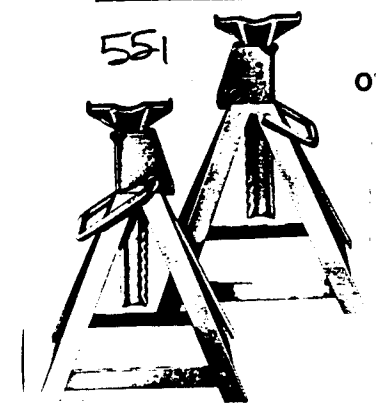

JACK STANDS

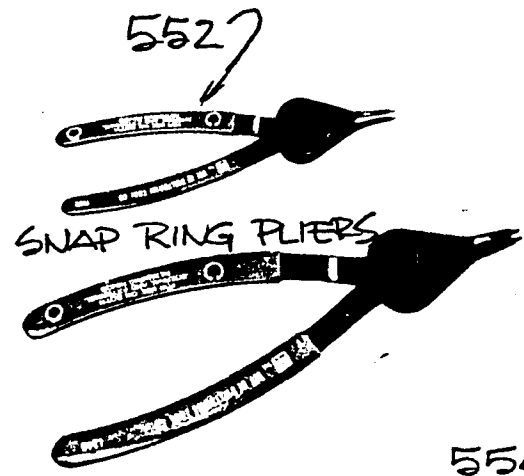

SNAP RING PLIERS

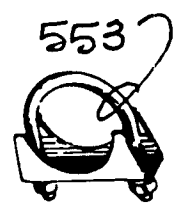

MUFFER CLAMP

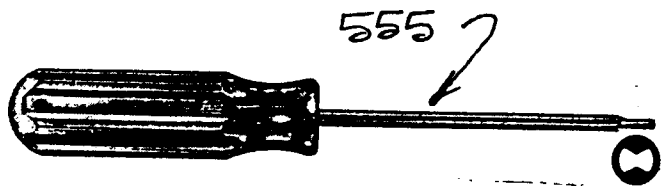

PHILLIPS SCREWDRIVER

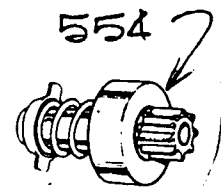

RING GEAR

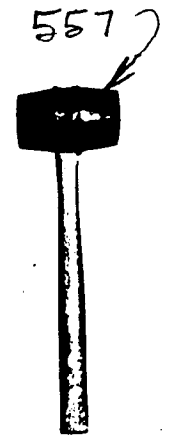

RUBBER Mallet

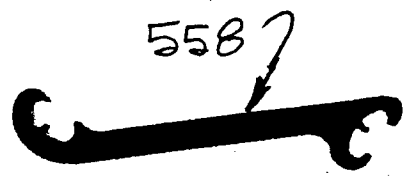

TIE ROD ADJUSTER

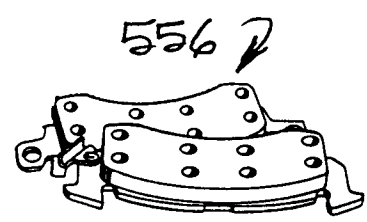

BRAKE SHOES



20A

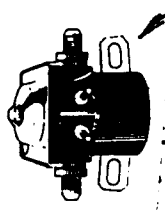

STARTER RELAY

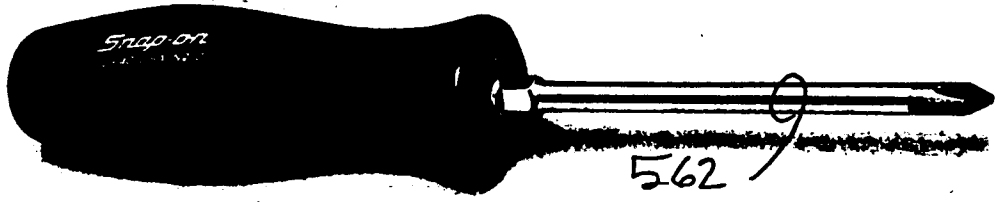

TORX TIP SCREWDRIVER

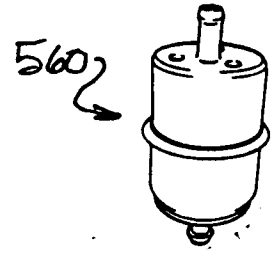

OIL FILTER