

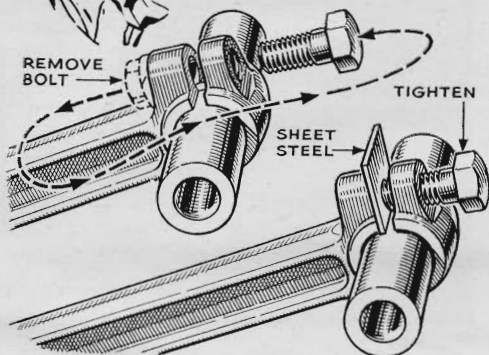

## Hints from the Model Garage

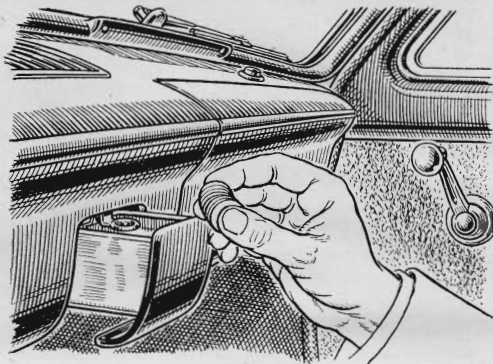

**Con Rod Pressed Open.** Wrist pins to be clamped in connecting rods of the kind shown will not always go in easily, even with the bolt loosened. If assembly proves difficult, reverse the bolt as shown and use it and a piece of thin steel to spring open the con rod very slightly. Replace the bolt in its proper position after doing this.



**Coins Kept in Ash Tray.** If you are a nonsmoker, the dashboard ash tray is a handy place to keep a supply of pennies, nickels, and dimes for parking meters and toll gates. For convenience in removing the coins, bend down the snuffer. Felt or cotton lining cemented to the bottom and sides will stop rattles.

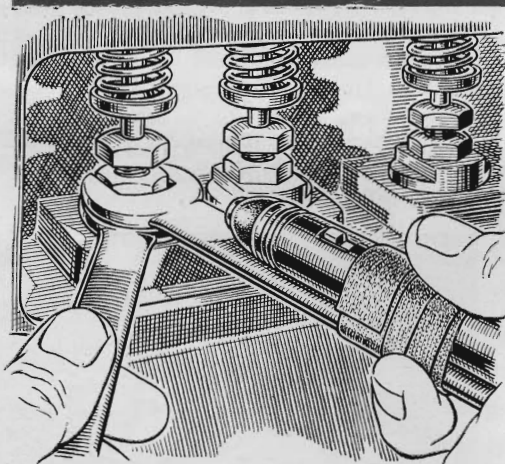

**Light on the Spot.** Adjusting valve tappets on a car is a fussy job to do just right. What makes it troublesome is the necessity of manipulating wrenches and a thickness gauge in cramped quarters with inadequate light. Albert S. Eaton, of Belmont, Mass., reports that the work goes a little easier if you tape a pocket flashlight to the upper tappet wrench.

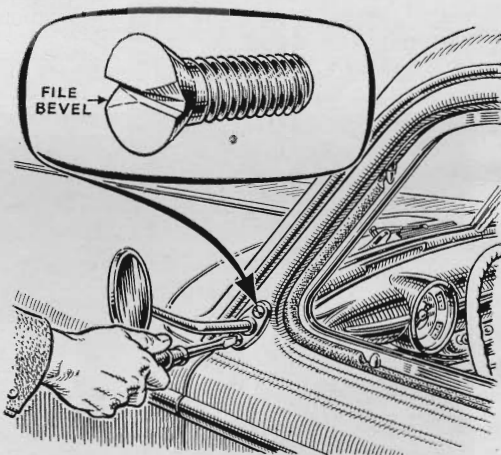

**Filed Screws Prevent Theft.** If you attach a mirror, road light, or other accessory with external screws, safeguard it against theft by filing off those corners of the slots that the screwdriver bears against during removal. Once tightened, the screw is next to impossible to remove, so use it only on permanent installations. You can retighten it, however, if vibration loosens it.

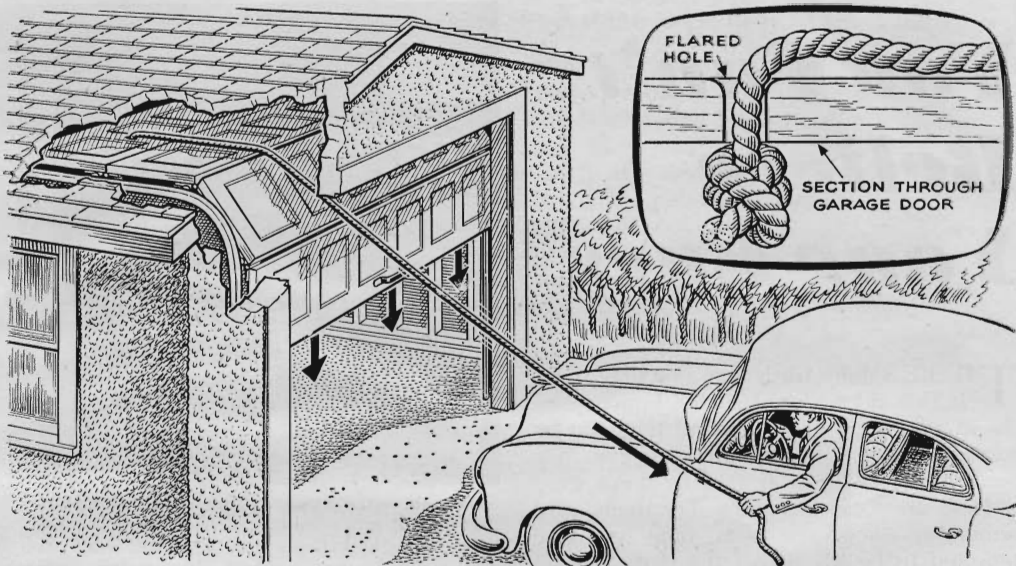

**Rope Closes Overhead Door.**

With this arrangement, you don't have to get out of the car to close the door after leaving the garage. Just grab the rope dangling near the jamb, and give it a pull after you have backed out. Attach the rope (a

clothesline will probably serve) by drilling a hole a few inches down from the top of the door. Charles Morse, Elmira, N. Y., says he finds the rope trick very convenient. For easy operation of the door, keep the rollers and track well lubricated.



**Tire Cushions Towing Bumps.**

An old tire makes an excellent coupling to a car that you want to tow. Pass a few turns of heavy wire or rope around the tire and the respective bumpers of the two cars and you are ready to go. The tire effectively smooths out the jerks and nicely cushions the bumps in stopping, writes Leslie H. Housel, of Grass Lake, Mich.

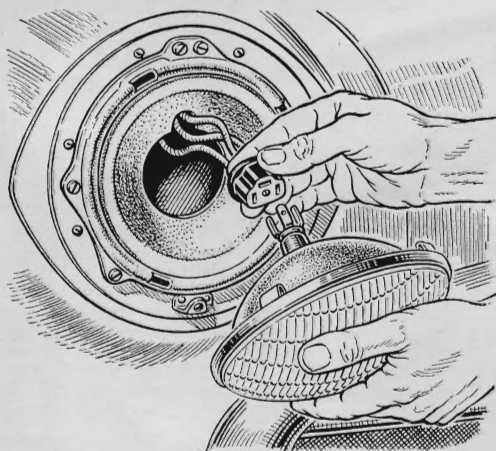

**Corrosion Knocks Out Lights.**

If either beam of a sealed-reflector headlight goes out, be sure you really need a new unit before putting down the cash. In some cases, particularly in older cars, you will find the contacts have become so corroded that the resistance prevents the lamp from lighting. Careful cleaning of the contacts will restore the light to usefulness.