

Hints From the

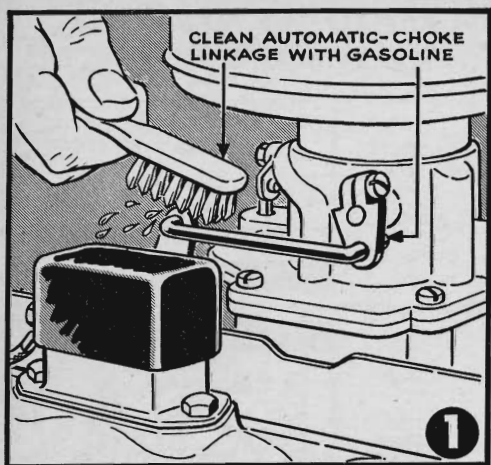

1. Automatic chokes sometimes get blamed unfairly. Here at the Model Garage we've learned to look first at the linkage between the carburetor and choke-control mechanism. Oil on the connecting lever will gum it up and make the choke sluggish. A toothbrush dipped in gasoline removes oil and dirt; very often that's all that is needed.

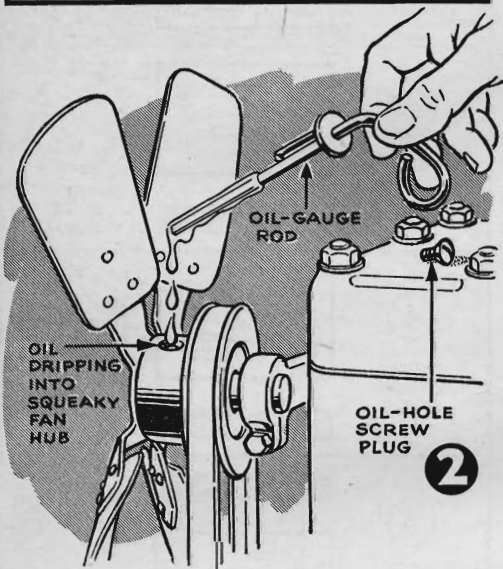

2. Fan Squeak Gives Warning. Many fans start to squeak when lubrication is neglected, and a scored shaft is never far behind. Marion L. Rhodes, of Knightstown, Ind., heard the warning noise, but he was on the road, had no oil can, and was miles from a service station. To forestall trouble, he removed the screw plug and held the oil dip stick over the opening.

3. Freeze a New Insert Ring. If valve inserts are being replaced and don't come out easily, remove with a drill and chisel, taking care not to damage the recess. Pack new rings in dry ice for at least 15 minutes to shrink them.

4. Magnets Peg Things to Dash. Cigarettes, sun glasses, and the like are always in reach for William G. Hykle, Montreal, who uses magnets to hold them up against the windshield frame on his car's sloping dashboard. Felt glued under each magnet keeps it from scratching.

Drawings by Stewart Rouse

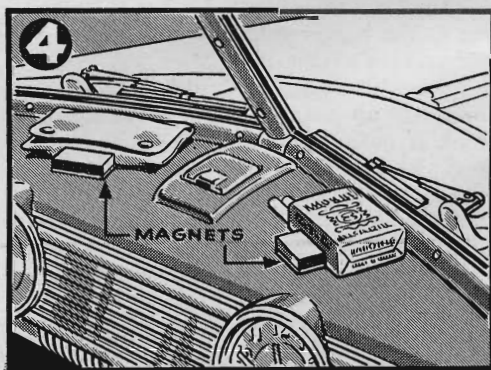
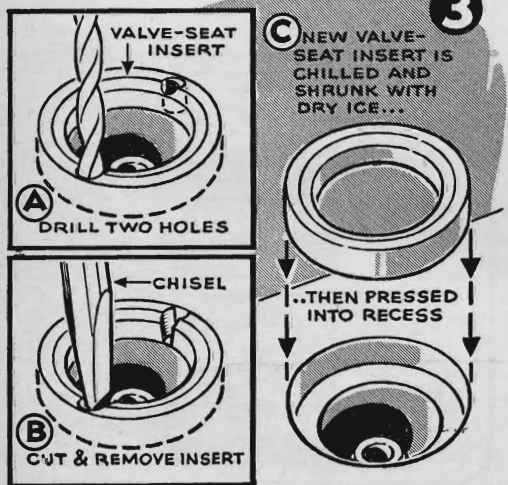

Model Garage

5. Grease Stops Squeak. A persistent squeak when you turn the steering wheel may come from the spring-cushioned end of a drag link that hasn't been lubricated properly because the grease didn't reach the spring. The squeak can be stopped by drilling a tiny hole in the housing and forcing grease directly to the spring.

6. Gauging Brake-Drum Wear. John Krill, of North Lima, Ohio, reports that one truck-fleet superintendent uses a straightedge and .010" wire to determine if brake-drum scoring is bad enough to demand machining. If the wire passes through any groove, the surface is considered in need of refinishing.

7. Blow Out the Dirt. One thing you'll never see in the Model Garage is a mechanic grab a wrench and remove a plug without preliminaries. Dirt should first be blown from the seat with an air hose—or failing that, a tire pump.

8. Cycle Footrest Repaired. If a crack occurs in the rubber casing of a motorcycle footrest bar, cut a disk out of 16-ga. brass, cup with a ballpeen hammer to conform to the casing, and drill the disk and shank for a 3/16" screw. Turning up the screw will close the crack. I. J. Stretten, Detroit, makes the suggestion.

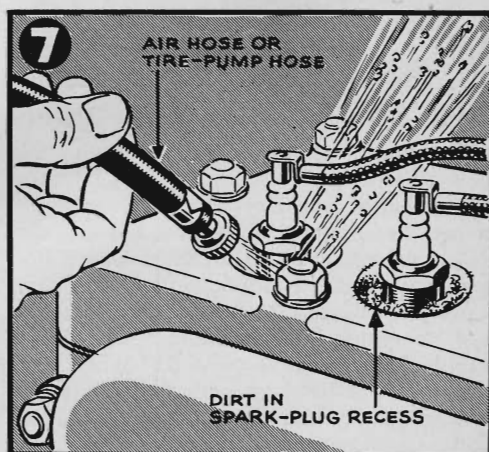
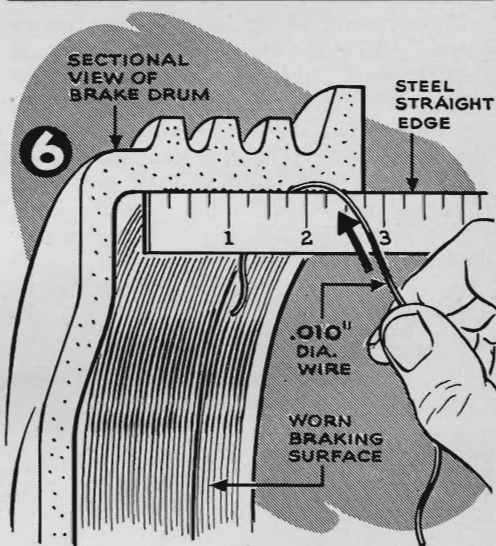
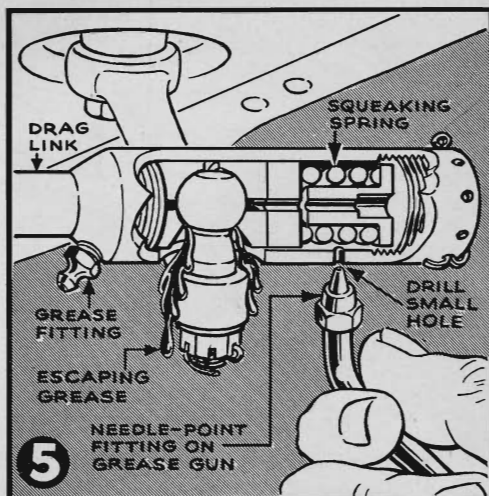

Gus Wilson

