

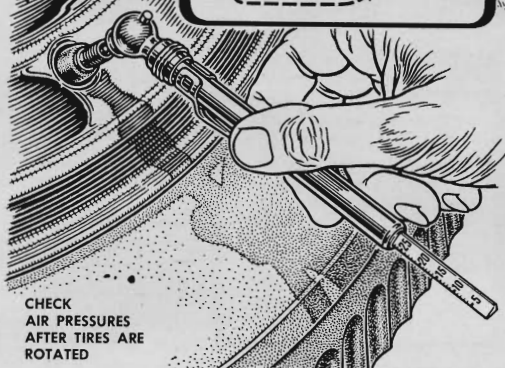

Hints from the Model Garage

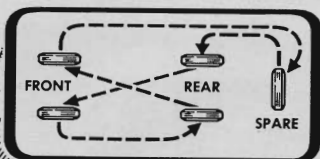

CHECK
AIR PRESSURES
AFTER TIRES ARE
ROTATED

After switching tires, remember to check pressure in the new position. Front tires should carry a few more pounds than rear, and rotating puts the softer rear tires up front (see rotation chart above) where they may prove to be underinflated.

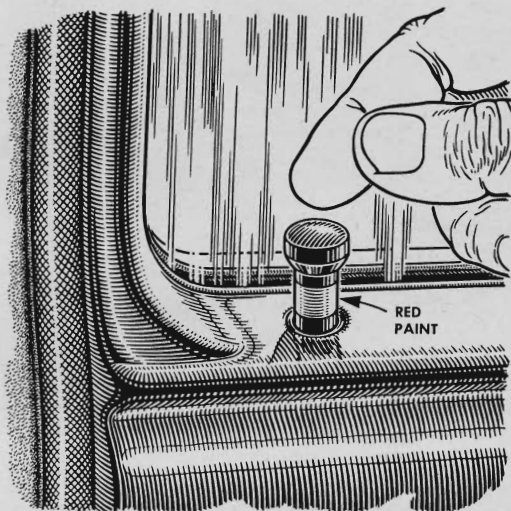

Checking door-lock buttons to see that they're down can be done with a glance if you put a band of red paint or colored tape on them. When the buttons are pressed down, the bands disappear. If you can see a band, the door is unlocked.



A good makeshift creeper for work beneath your car can be had from a large carton opened flat. It can be shifted about easier than papers or a cloth and the thick board gives your back protection from damp or greasy ground or concrete.

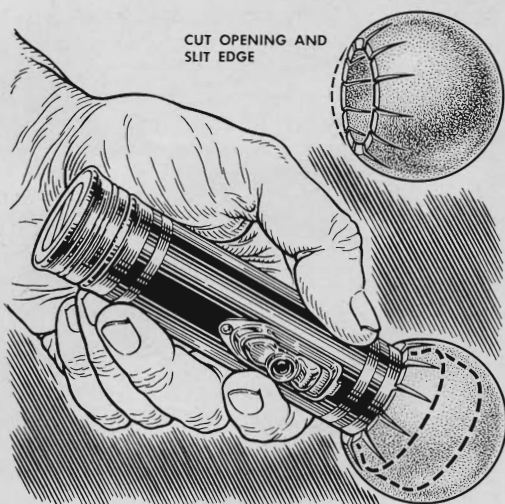

Cap the lens of a flashlight with a rubber ball to protect it while being carried in the trunk, glove compartment or tool box. Cut an opening in the ball, then slit the edge of the opening so it can easily be forced over the lens of the flashlight.

More Hints from the Model Garage

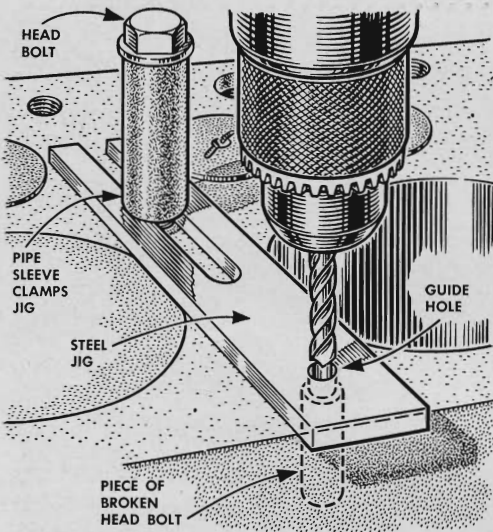

To drill out a broken bolt without damaging the threaded hole, clamp a simple jig under an adjacent bolt to center the drill. To make the jig, cut a slot in one end of a steel strip and drill a guide hole near the other end for the drill bit.

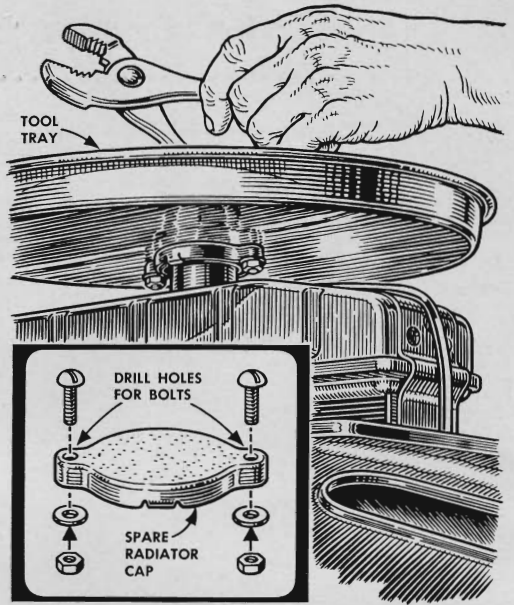

A tip-proof tool tray can be made by bolting a large pie tin or serving tray to the top of a spare radiator cap. Mounted on the radiator's filler neck in place of the regular cap, the tray is handy as you work in the engine compartment.

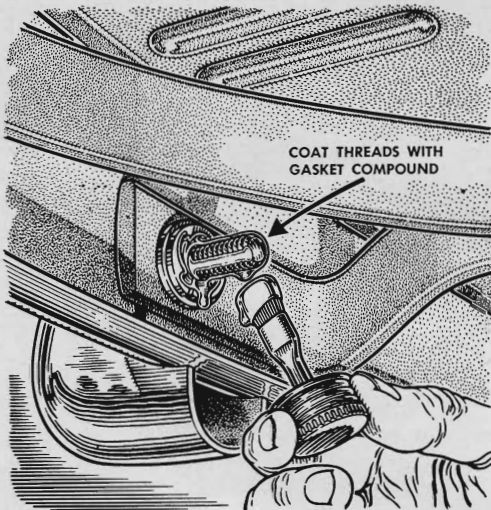

A coating of gasket compound over the protruding end of a bolt exposed to the weather will keep it rust-free and easy to remove. Protect license-plate bolts this way, and coat bumper-bracket bolts, fender and body bolts when new.

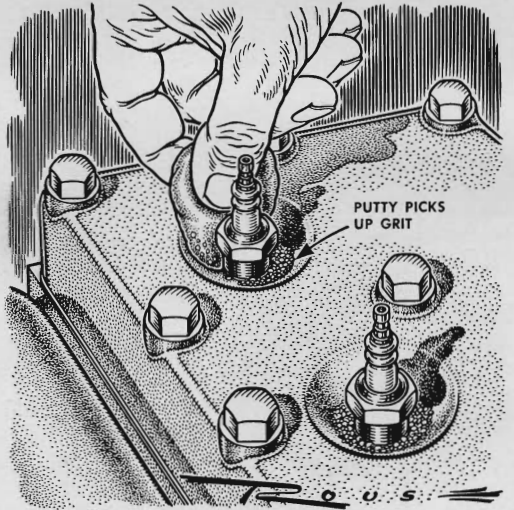

Pick up dirt and grit from spark-plug wells, so plugs can be removed without contaminating the cylinders, with a ball of putty or wallpaper cleaner. Press it in firmly, close to the plug. When you lift it out, the grit will adhere to it.