

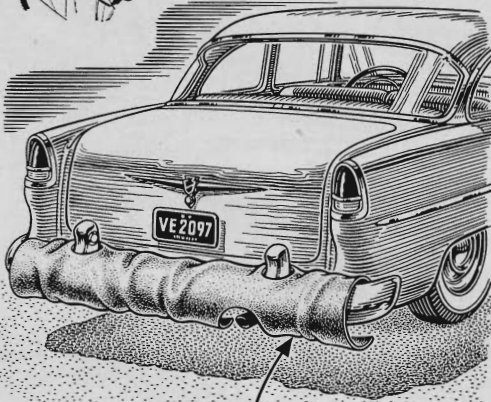

Hints from the Model Garage

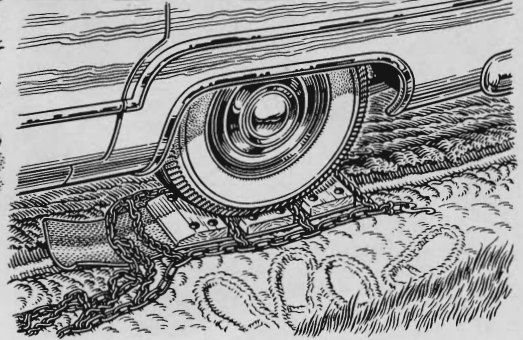

PIECE OF TRUCK INNER TUBE HELD IN PLACE BY HOLES WHICH GO OVER TOPS OF BUMPER GUARDS

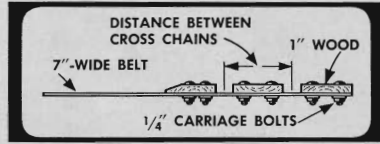

Chrome saver—that's what one man calls this strip of truck inner tubing. The bumper guards, projecting through holes, hold it over the bumper to protect the chrome when he has to be pushed.

Wood blocks help put chains on to get out of mud. Move the car forward as far as you can, put the blocks, with the chains on top, behind the wheel, back onto the blocks, and then fasten chains.

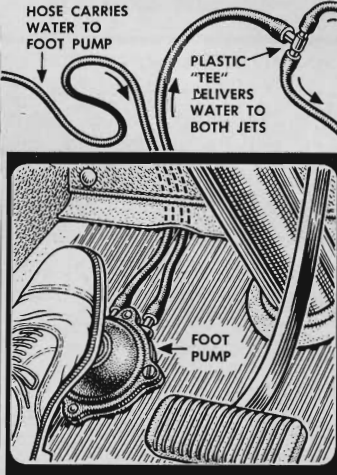

Running water in your car—for drinking or washing small fingers sticky with candy—is simple to install if you adapt a windshield-washer kit available from accessory stores for about \$5.

The kit includes a jar with a bracket

that is screwed to fire wall or trunk, a foot-operated pump that goes near the headlight-dimmer switch, rubber tubing, and two jets. For your water supply, simply mount the jets in holes in the dash instead of outside the windshield.

More Hints from the Model Garage

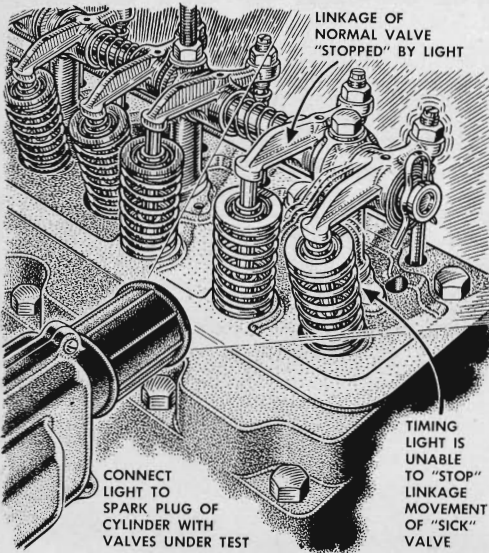

Try a timing light when you suspect sticking valves. When the cylinder fires, the valves should be closed—and both valve stem and spring will appear stationary under the timing-light flash. If there is sticking, you will see a hesitant movement of valve stem or spring.

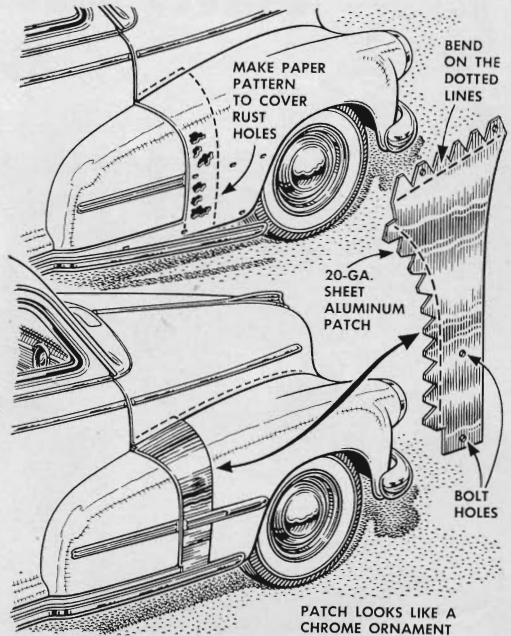

A quick fix for a rusted fender is an overlay of sheet aluminum—it looks like extra chrome. Remove trim pieces and make a paper pattern of the area. Snip the aluminum, then stretch and hold it in position with bolts concealed by the hood and trim. Scallops lock it tighter.

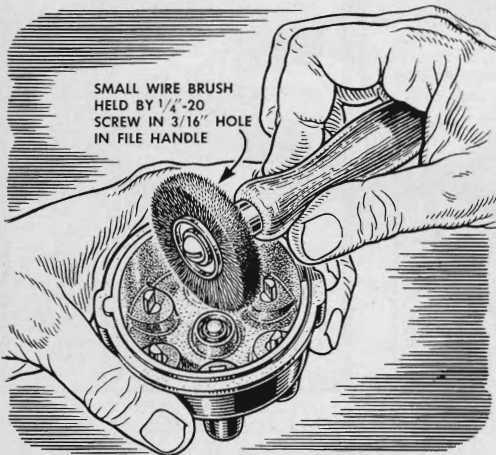

Distributor troubles sometimes come from hard-baked deposits that a cloth won't clean out. They yield readily to a fine wire brush, 2" or 2½" in diameter, that you can mount in a file handle.

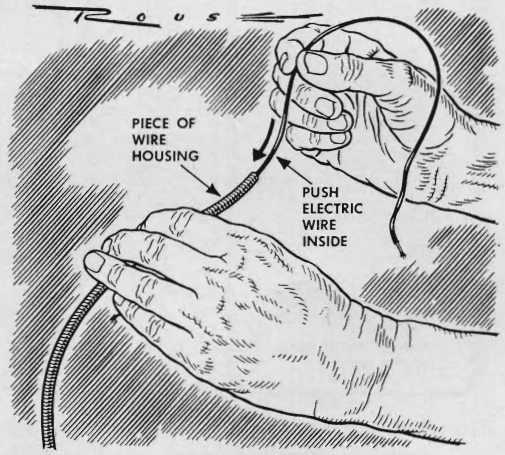

To protect auto wiring that is subject to heavy abrasion, make up your own miniature BX cable by threading the wires through the flexible armor used to sheathe speedometer cables or choke wires.