

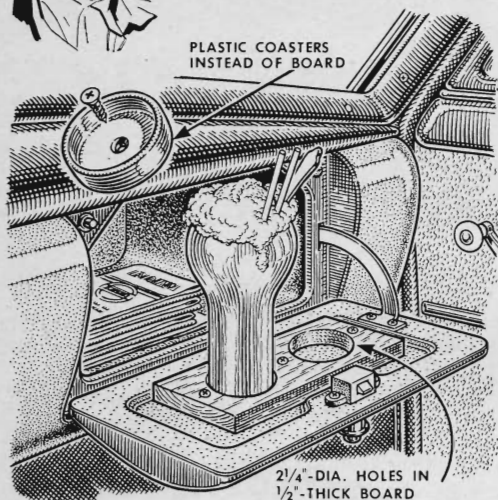

# Hints FROM THE MODEL GARAGE

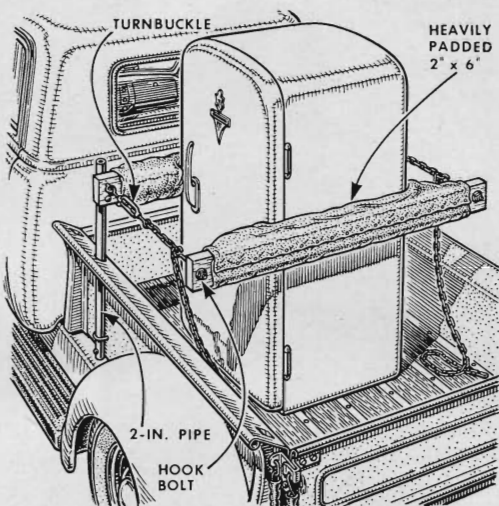

**Balancing a soda glass** while stopping for a roadside snack is no problem if you attach the glove-compartment lid with a holder made from scrap wood. Deep-rimmed plastic coasters serve as well if attached with flat-head sheet-metal screws.



**Heavy, padded braces** at front and back prevent slipping and scuffing when you move a partial load in a truck. Link the holding chains as taut as possible to the free-riding rear brace, then tighten with the turnbuckles to hold the load fast.

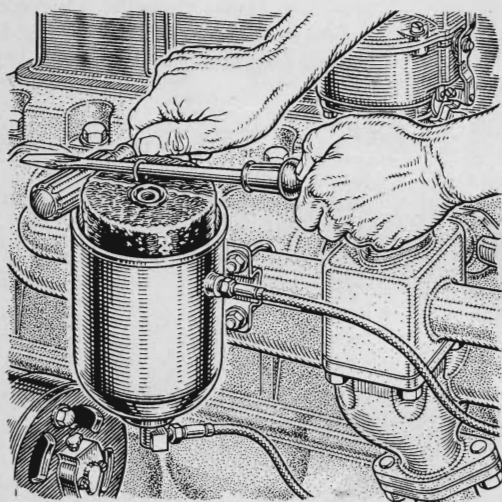

**Two screwdrivers**, with the handle of one used as a fulcrum, provide the leverage you need to start a stuck oil-filter refill without yanking off the wire handle. Take care not to nick the sealing seat of the housing, or leakage may result.

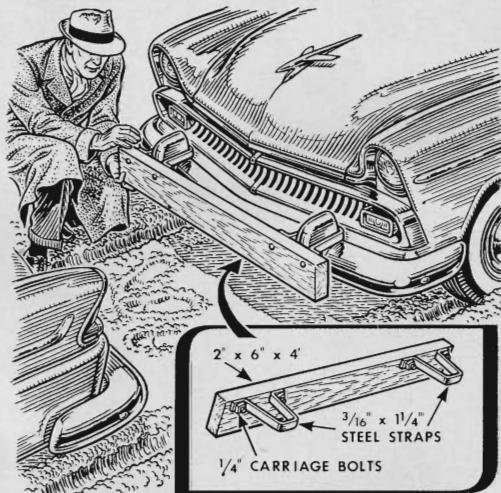

**Bumper and grille protection** when you are called upon to push—or need pushing—is carried in your trunk with a guard made from a short length of stout lumber. Bend and bolt on the steel straps so that they fit loosely over the bumper guards.

## ***MORE*** Hints from the Model Garage

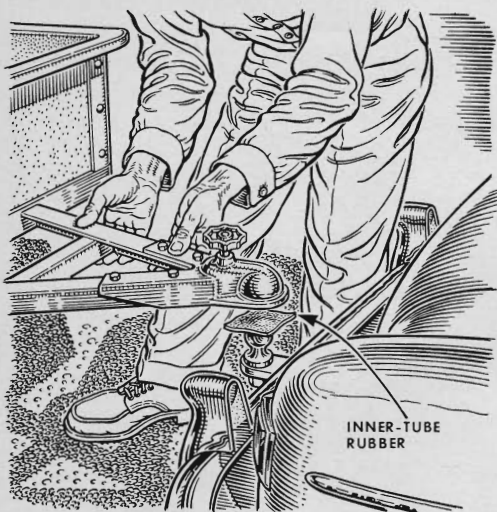

**Rubber padding in the socket joint** of the hitch will give you a nonrattling coupling that won't click and jerk when you pull a light trailer. Just lay a square of old inner-tube rubber on the ball before dropping the hitch on it.

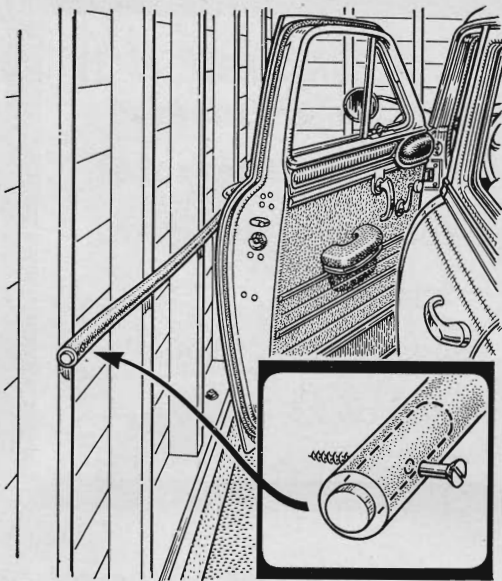

**Discarded garden hose used as a bumper** on your garage wall protects the car door when you open it to get in or out. Drive a short dowel in each end and drill for a mounting nail or screw. Use a concrete nail or expansion bolt in a masonry wall.

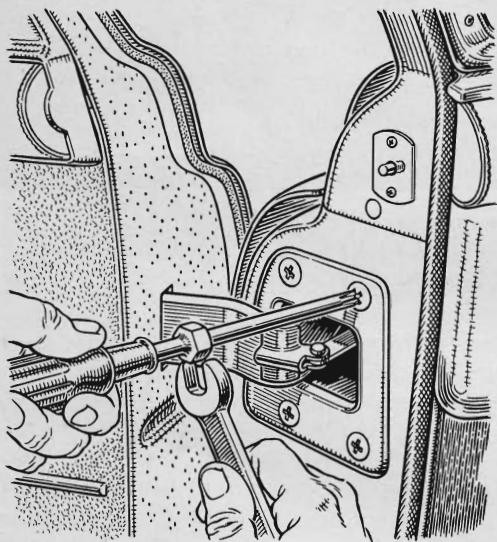

**Turning a screwdriver** while tightening or removing a door hinge can be made easier if you braze a nut on the shank near the handle. Then put pressure on the end of the screwdriver and do the turning with a small open-end wrench.



**Model-airplane dope** or fingernail polish will cut down annoying glare from dash lights. Simply dip the bulbs in the red dope and let dry. Then, checking as you work, start at bottom and gradually scrape off coating until light level is just right.